



# PSA-3002

## Compact PowerSync® Analyzer

IEEE 802.3at Power over Ethernet

### Product Overview

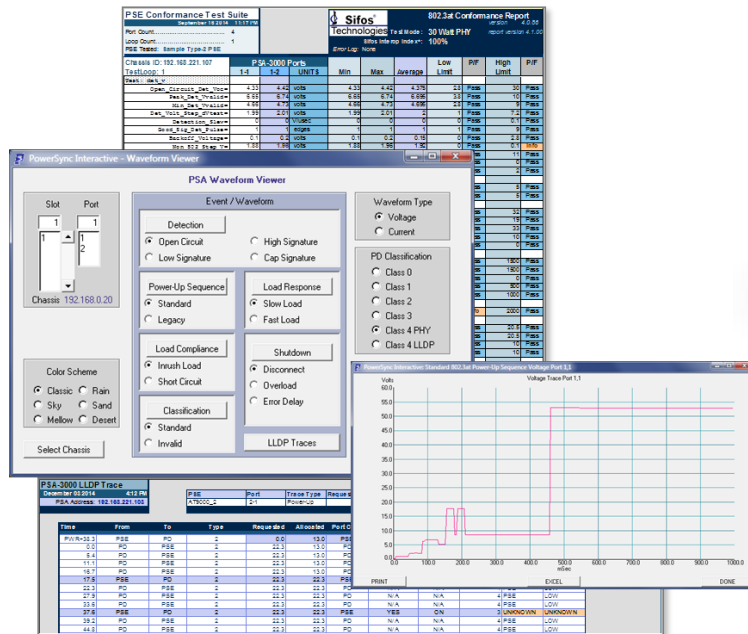

## Key Features

- Industry Leading IEEE 802.3at PoE PSE Conformance Tests
- Replaces All General Purpose Test Equipment & Fixtures
- Small, Light Weight, Transportable
- Continuous PSE Loading > 42 Watts Per Test Port (2 Test Ports)
- Continuous 4-Pair PSE Loading to 75 Watts (Single Port)
- One-Button 2-Pair and 4-Pair PSE Waveform Analysis
- Flexible Powered Device LLDP Emulation and LLDP Analysis
- Flexible and Accurate Measurements of Voltage, Current, Noise
- Noise Immune Triggering, Transients, and Time Interval Measurements
- Supports PSE Packet Transmission Testing with PoE Loads
- High Level Script Automation and Graphical User Interface
- Software Compatible with Sifos PSA-3000 Family

**Verification, Simplified.**

## **IEEE 802.3at and Pre-802.3bt PSE's**

End-Spans

Mid-Spans

PoE/PoE+ Connectors

Injectors

## **Fully Automated 802.3at PSE Conformance Test**

Comprehensive Hardware /  
Firmware DV Testing

Device Qualification

LLDP Protocol Analysis

Interoperability Analysis

Quality Assurance

## **Compact but Capable**

Visualize Common 802.3at  
and pre-802.3bt (4-Pair) PSE  
Behaviors and Responses

Prototype Tests and  
Software for PSA-3000

Troubleshoot PSE Ports  
Anywhere

## **Portable PoE Service Analyzer**

Automated PoE Service  
Outlet Interoperability  
Analysis

## **Overview**

Power-over-Ethernet (PoE) challenges design and test engineers to evaluate multi-channel, "intelligent" DC power sources that are activated and deactivated through signaling protocols operating over several power delivery and polarity configurations. The application and management of DC power over multiple local area network connections must be completely transparent and non-disruptive to the traditional data transmission functions of those network connections.

### **One Box Solution**

Sifos Technologies provides a **one-box solution** to facilitate complete testing and analysis of Power Sourcing Equipment (PSE) behaviors and overall compliance to the **IEEE 802.3at** specification. Each test port inside a PowerSync Analyzer is an autonomous and fully isolated instrument offering a rich set of stimulus and measurement resources. Test ports are configured and controlled via a high level automation interface, **PowerShell PSA**, and may also be accessed and managed from an intuitive graphical user interface, **PSA Interactive**.

### **Automated PSE Conformance Testing**

The PSA-3002 may be optioned via a license key to run the world's most advanced **PSE Conformance Test Suite**. This fully automated application applies the PowerSync Analyzer's diverse resources to assess over 70 IEEE 802.3at specification parameters per port, presented in easily readable spreadsheet reports with port statistics and clearly notated pass/fail limit analysis.

### **LLDP Emulation**

The IEEE 802.3at specification describes a new generation of PSE's and Powered Devices (PD's) that communicate highly resolved power needs and power allocations using Ethernet layer 2 (LLDP) link protocols. The PSA-3002 may be optioned via a license key to flexibly emulate PD's and fully analyze the power negotiation protocols between PSE's and PD's.

### **Getting Ready for 4-Pair PoE (802.3bt)**

The PSA-3002 has the ability to internally combine both test port resources for the purpose of emulating a variety of 4-Pair PD signatures and power loads with continuous power loading up to 75 watts. 4-Pair metering of load power, load current, voltage-per-pair, power-per-pair, and current-per-pair is readily accessed through menus in **PSA Interactive** and through high level **PowerShell PSA** commands. **PSA Interactive** offers Standard Waveforms to allow visual analysis of PSE signaling, power-up, load response, disconnect (2 or 4 pair), and overload (2 or 4 pair) responses. PD emulation is flexibly configured to work with a variety of proprietary 4-Pair PSE's including UPoE PSE's deploying extended LLDP protocols for 4-pair powering.

### **Start Small and Grow**

The PSA-3002 is well suited to early device qualification and design verification applications as well as to field application and support activities. Test plans and software developed with the PSA-3002 are readily extendable into PSA-3000 (24-port) and PSA-3048 (48-port) test platforms.

**Verification, Simplified.**

## PowerSync Analyzer Test Equipment Setups

### PSE DV, QA Test

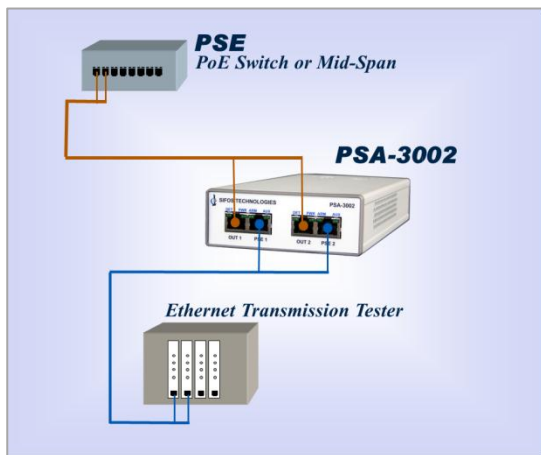

### PSE DC Unbalance Tolerance

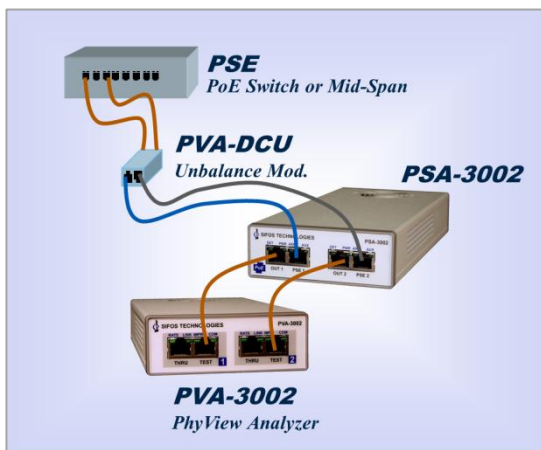

### PoE Service Analysis

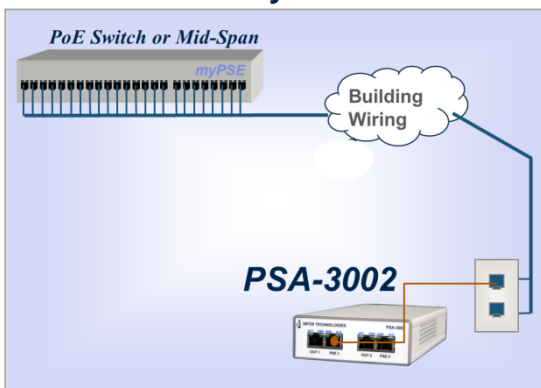

### Per-Port PSE Test Resources

Flexible PD Detection & Class Emulation

Flexible Loads and Load Transients

Event or Edge Triggering of Load Transients & Measurements

Average, Peak (Min/Max), and Trace Measurements of Port Voltage and Load Current with Flexible Sampling Apertures

Standard One-Button Waveform Library for Rapid PSE Analysis and Conformance Troubleshooting (including 4-Pair PSE's)

Flexibly Triggered, Noise-Immune Time Intervals / Slews O-Scope Graphical Waveforms (802.3at and 4-Pair PSE's)

LAN Termination, LLDP Protocol Emulation and Tracing

Concurrent Packet Transmission and PoE Load Testing

External Trigger Input/Output

4-Pair PoE Loading and Analysis (Port 2 only)

### PSE Conformance Suite\*

High Coverage, Fully Automated IEEE 802.3at PSE Compliance Testing and Analysis (including LLDP)

23 PSE Tests Producing Over 70 802.3at Parameters / Port Automated Test and Port Sequencing with Comprehensive, Colorful Spreadsheet Reporting

Automatically Adapts to PSE Device Technologies

> 95% 802.3at PSE PICS Coverage

Regularly Updated with Sifos Tracking Service Agreements

### LLDP\*, PHY, Transmission Test Support

Flexible, Per-Port, Programmable PD LLDP Emulation for PoE with Payload, Timing, & Synchronization Control

Fully Automated LLDP Protocol Traces and Analysis

PSE Side LLDP Emulation and Protocol Traces

Cisco UPoE PD LLDP Support (PD Emulation)

Test Port "Through" Channel for 10/100/1000 PHY Testing (using the Sifos PVA-3000) and LAN Transmission Testing

Negligible Through-Channel LAN Impairment

### PoE Service Analyzer

Comprehensive Evaluation of PoE Service at a PD Interface

PoE Service Interoperability Analysis

In-Band Control of PoE Service-Under-Test

Colorful Spreadsheet Reporting

### Powerful Software

PSA Interactive GUI for Control of all Test & Diagnostic Resources

Automated Test Menus for PSE Conformance and PoE Service Test Suites

Comprehensive, User-Friendly PowerShell Script Development and Execution Environment Built on Tcl/Tk

\* Available as an optional feature to the PSA-3002. See feature-specific data sheet.

## PSA Interactive Graphical User Interface

The Sifos PSA Interactive graphical user interface (GUI) is a flexible and powerful tool designed to allow users to quickly configure and perform both standard and user-defined measurements on IEEE 802.3 compliant power sourcing equipment (PSE). PSA Interactive provides an intuitive view of the full range of testing resources available within the PSA-3002 PowerSync Analyzer. Users can quickly harness the flexibility and power of these resources to perform design verification and diagnostic measurements or to prototype sequences that will eventually be automated in PowerShell PSA scripts.

PSA Interactive organizes PSA-3002 resources and testing features into a variety of distinct subsystems\*:

- Port Detection Configuration
- Trigger Configuration
- Load and Load Transient Configuration and Activation
- DC Meters (Average, Max Peak, Min Peak, and Trace Voltage and Current meters)
- AC Peak Voltage Meter
- Time Interval / Slew Rate Meter
- PSE Conformance Tests
- PSE Conformance Test Sequencer
- Standard Waveforms & PD LLDP Emulation / Testing
- 4-Pair PSE Signature, Load Configurations and Metering (including Standard Waveforms)
- PSE LLDP Emulation / Testing

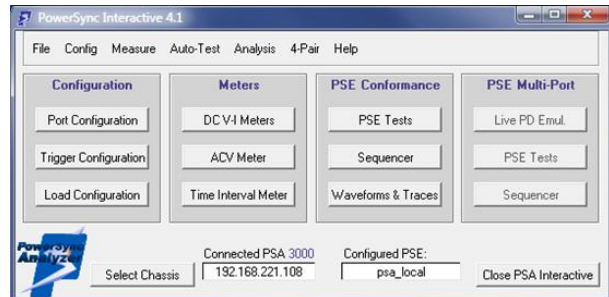

PSA Interactive Main Menu

PSA Interactive enables rapid single or two-port configurations and one-button testing and analysis through intuitive subsystem dialogs that flexibly address test ports and PSA chassis.

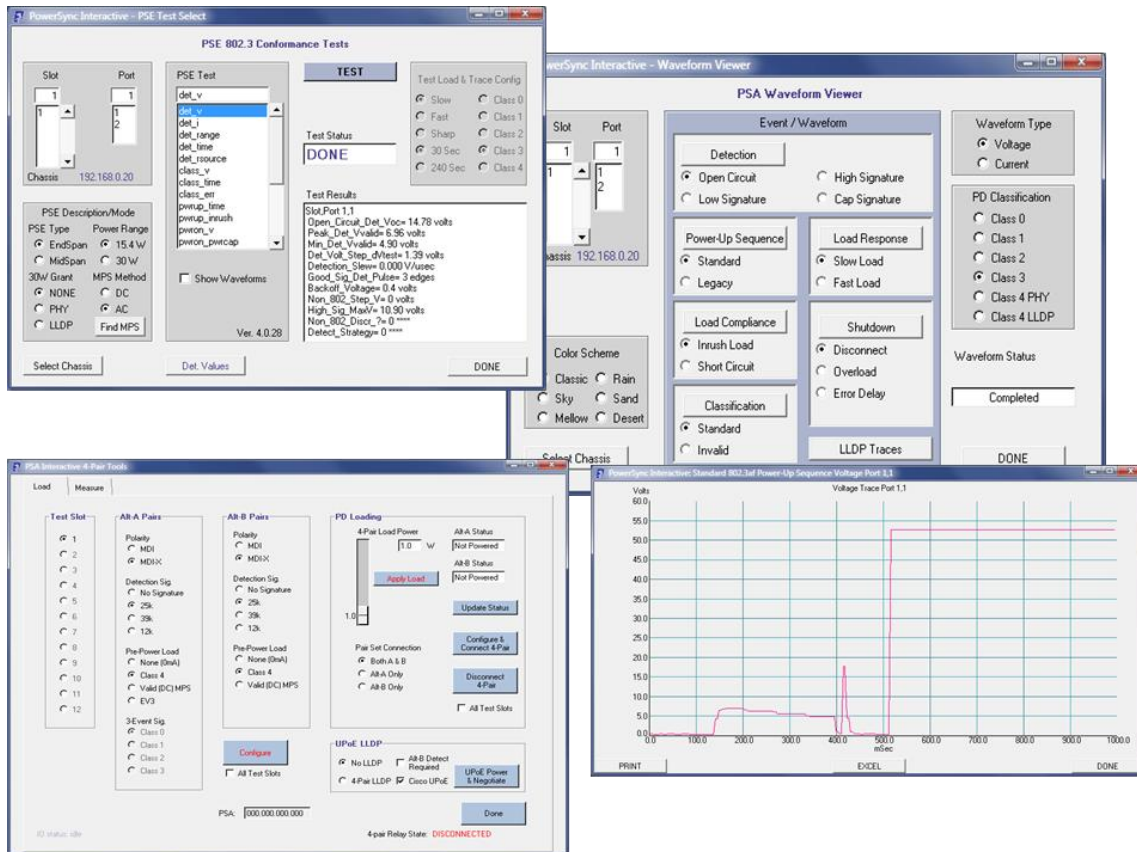

PSA Interactive Menus for PSE Conformance Selected Test, Standard One-Button Waveform Analysis, and 4-Pair PSE Signature and Load Configuration

\* PSA Multi-Port Suite Features and Menus are not available on the PSA-3002.

## PowerShell PSA Tcl/Tk Interface

The PowerShell PSA Scripting Environment provides a high level, interactive means to control and program automated test sequences for the PSA-3002 PowerSync Analyzer. PowerShell enables fully automated testing suites that span multiple ports, blades, and instruments. Built upon the popular Tool Command Language (Tcl), it offers an extensive and extensible programming language well suited for automated testing.

PowerShell PSA provides a complete API for the PSA-3002 including high level commands that execute and sequence standard **802.3 PSE Conformance Tests** and **LLDP Protocol Analyzers**. PowerShell PSA commands access all of the resources of the PSA-3002 and enable the rapid development of highly customized test scripts. PowerShell PSA supports off-line script development and debug through its robust built-in emulation mode.

PowerShell PSA libraries can be integrated into broader Tcl environments that interlace traditional network transmission tests with Power-over-Ethernet tests. This enables seamless integration of custom or standard PSE tests with existing Tcl-based test suites.

Other features offered by the PowerShell PSA environment include:

- Interpretive command execution (no compilation, easy debug)
- Simple, intuitive PowerSync Analyzer commands (API)
- Integrated and extensive command “help” features
- Fast test execution speeds
- DUT-specific configuration files to configure settings
- Supports sequencing of test suite sequences and DUT-specific report routing
- Use sided-by-side with PSA Interactive GUI
- AnyEdit PSA Smart Editor for PowerShell PSA
- Traditional Tcl Console
- Command-Knowledgeable Wish Console with PSA waveform viewer capability

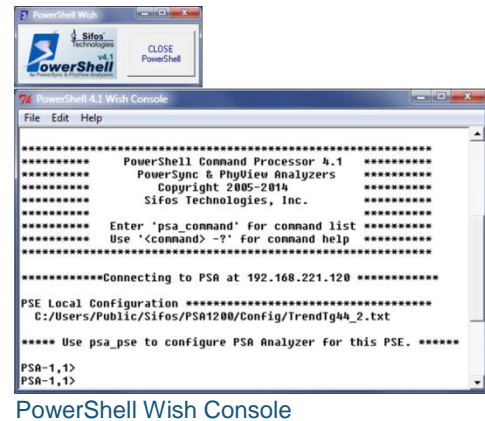

PowerShell Wish Console

## IEEE 802.3 PSE Conformance Test Suite

The IEEE 802.3at PSE Conformance Test Suite is a library of **fully automated, flexibly sequenced, and self-adapting** tests that provide a high degree of specification compliance testing on PSE ports without the need for any external instrumentation. The PSE Conformance Test Suite may be used to fully assess interoperability of one or more PSE ports given a single button press or single command. Colorful Microsoft Excel spreadsheet reports analyze all test results relative to IEEE 802.3at specification parameters, flagging failures and compiling statistics.

The PSE Conformance Test Suite serves as a virtual industry standard for PSE specification compliance. Testing can be completed without deep, internal knowledge of the 802.3at standard and without high expertise in PSA-3002 capabilities. Test coverage **exceeds 95%** of 802.3at PSE PICS.

See Sifos datasheet, **PSE Conformance Test Product Overview**, for further information regarding the 802.3at PSE Conformance Test Suite.

## PoE LLDP Emulation and Analysis

The PSA-3002 includes a subsystem designed to flexibly emulate LLDP capable PD's (and PSE's) on a per test port basis. Fully automated applications allow in depth capture and analysis of protocol between the PSE and the PD.

Time	From	To	Type	Requested	Allocated	Port Class	MDC Capability	MDC Status	Power Class	Source	Priority
10.8	PSA	PD	LLDP	13.0	13.0	PSSE	YES	ON	4	PRIMARY	LOW
10.9	PD	PSA	LLDP	22.3	13.0	PD	N/A	N/A	4	PSE	LOW
1.2	PSSE	PD	LLDP	22.3	22.3	PSSE	YES	ON	4	PRIMARY	LOW
1.4	PD	PSSE	LLDP	22.3	22.3	PD	N/A	N/A	4	PSE	LOW
11.1	PD	PSSE	LLDP	22.3	22.3	PD	N/A	N/A	4	PSE	LOW
18.2	PSSE	PD	LLDP	22.3	22.3	PSSE	YES	ON	4	PRIMARY	LOW
18.7	PD	PSSE	LLDP	22.3	22.3	PD	N/A	N/A	4	PSE	LOW
22.2	PD	PSSE	LLDP	22.3	22.3	PD	N/A	N/A	4	PSE	LOW
28.0	PD	PSSE	LLDP	22.3	22.3	PD	N/A	N/A	4	PSE	LOW
31.6	PSSE	PD	LLDP	22.3	22.3	PSSE	YES	ON	4	PRIMARY	LOW
33.9	PD	PSSE	LLDP	22.3	22.3	PD	N/A	N/A	4	PSE	LOW
39.3	PD	PSSE	LLDP	22.3	22.3	PD	N/A	N/A	4	PSE	LOW
45.0	PD	PSSE	LLDP	22.3	22.3	PD	N/A	N/A	4	PSE	LOW

LLDP Protocol Trace

See Sifos datasheet, **LLDP Emulation and Analysis Overview**, for further information on this topic.

## PoE Service Analyzer Application

The PoE Service Analyzer is a special automated test and reporting application to enable comprehensive parametric and interoperability analysis at any PD connection point in a PoE enabled wiring plant.

See **Sifos Technologies, PoE Service Analyzer Product Overview** for further information regarding the PoE Service Analyzer.

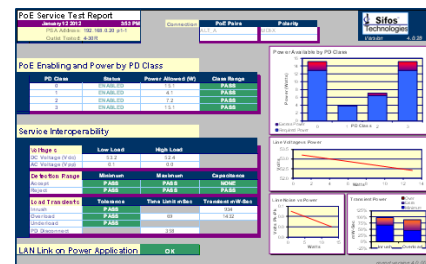

Service Analyzer Report

## Technical Data: PSA-3002

LAN Interface Specifications			
Operating Mode	Signal Path	Parameter	Specification
Data Through Mode	PSE-# to OUT-#	Connections	RJ45
		Data Rates and Signaling	10/100/1000BaseT
		Latency	0 ( Passively Coupled)
		Impedance	100Ω, Balanced
		Pair-Pair Isolation	≥ 36dB @ 100MHz
		Insertion Loss	≤ 2dB, 0.1MHz to 100 MHz
		Insertion Loss Variation	≤ 0.75dB, 0.1MHz to 100 MHz
		Return Loss (OUT pairs terminated into 100Ω)	≤ -24dB, 1MHz to 100MHz
Data Connect (LLDP Emulation) Mode	PSE-# to Blade Transceiver	Connection	RJ45
		Data Rate and Signaling	10BaseT
		Orientation	MDI End Point
		Protocol	802.1ab, 802.3bc, 802.3at
		Impedance	100Ω, Balanced
		Return Loss	≤ -20dB, 1MHz to 100MHz

PoE Port Connections			
Operating Mode	Dependency	Parameter	Selections
2-Pair Power	Port 1 and Port 2 operate independently	Powered Pair	ALT-A or ALT-B
		Polarity	MDI or MDI-X
4-Pair Power	Connect to Port 2 (Port 1 bypassed)	Powered Pair	ALT-A and ALT-B
		Polarity	MDI or MDI-X for each pair

Detection and AC MPS Specifications			
Description	Conditions	Parameter	Specification
Detection Resistance	Vport = 2.5VDC - 12VDC, Port Connected, Transition Current Load = 0	Range	9 KΩ to 39 KΩ
		Resolution	1 KΩ
		Accuracy $\Delta V / \Delta I$ at 1 Volt Spacings	≤ 24KΩ, ± 250Ω > 24KΩ, ± 400Ω
Detection Capacitance	Vport = 2.5VDC - 12VDC, Port Connected, Transition Current Load = 0	Range	0.14, 5, 7, 11μF
		Accuracy	15%
Detection Signature Cut-Off Threshold	Port Connected	Vport	12V ± 2%
AC MPS Signature	Vport = 12VDC - 60VDC, Port Connected	AC Impedance	24KΩ    (0.1μF + 330Ω)
		Resistance Accuracy $\Delta V / \Delta I$ at 2 Volt Spacings	22.8KΩ, ± 250Ω
	Port Isolated	AC Impedance (≤ 500 Hz)	≥ 1.1 MΩ
		AC Impedance (≤ 120 Hz)	≥ 3.0 MΩ

Current Load Specifications			
Description	Conditions	Parameter	Specification
Load Current	Per Powered Pair	Range	0 to 750 mA
		Resolution	0.25 mA
		Accuracy	± 0.5% ± 0.25mA
		Slew Rates	> 4mA / μsec
		Activation Voltage	15V, Rising Vport
		De-Activation Voltage	14V, Falling Vport

Current Load Specifications			
Description	Conditions	Parameter	Specification
Transition (Mark Region) Current	Load Current Active, Per Powered Pair	Range	0 to 400 mA
		Resolution	0.25 mA
		Accuracy	$\pm 0.5\% \pm 0.25\text{mA}$
		Slew Rates	$> 4\text{mA} / \mu\text{sec}$
		Activation Voltage	14V, Falling Vport
		De-Activation Voltage	6V, Falling Vport
Configurable Load Transient	Vport > 15VDC	Sequential Load Steps	2
		Load Step 1 Range	0 to 1800 mA
		Load Step 2 Range	0 to 750 mA
		Resolution (0 – 1023 mA)	0.25 mA
		Resolution > 1023 mA	0.50 mA
		Accuracy	$\pm 1\% \pm 0.5\text{mA}$
		Slew Rate	$< 10\text{mA} / \mu\text{sec}$
		Step 1 Duration < 1024 mA	200 $\mu\text{sec}$ to 1 sec
		Step 1 Duration > 1023 mA	200 $\mu\text{sec}$ to 80 msec
		Step 2 Duration Load Step 1 < 1024 mA Load Step 1 > 1023 mA	200 $\mu\text{sec}$ to 1 sec (or persist) 1 sec
		Step Resolution	100 $\mu\text{sec}$
		Trigger Modes: < 1024 mA > 1023 mA	Immediate, Edge, Event Immediate
		Effective Load Source Resistance	37 $\Omega$
		Foldback Suppression Min. Port Voltage (@ 400mA PSE Current Lim.)	30 VDC
Foldback Suppression Duration	Step 1 + Step 2 Duration		

DC Metering Specifications			
Description	Conditions	Parameter	Specification
Voltage Meter	Average, Max-Peak, Min-Peak, Scope Trace	Voltage Range	0 - 60V
		Trace Length	256 Samples
		Sample Rates	39.1 $\mu\text{sec}$ – 39.1 msec (10msec -- 10sec traces)
		Resolution	0.025 V
		Accuracy1	$> 30\text{VDC}: \pm 1.5\% \pm 15.6 \text{ mV}$ $< 30\text{VDC}: \pm 2.0\% \pm 15.6 \text{ mV}$
		Measurement Triggers	Immediate, Edge, Event
Current Meter	Average, Max-Peak, Min-Peak, Scope Trace	Current Range	0 – 2000 mA
		Trace Length	256 Samples
		Sample Rates	39.1 $\mu\text{sec}$ – 39.1 msec (10 msec -- 10sec traces)
		Resolution (0 – 1023 mA)	0.25mA
		Resolution (1024 – 2000 mA)	0.5mA
		Accuracy2	$\pm 0.5\% \pm 0.5\text{mA}$
		Triggers	Immediate, Edge, Event

- Does not include Voltage drop due to cable losses and 0.45 $\Omega$  maximum test port input resistance.
- Does not include Port-Connected MPS current, which is approximately (Vport - 12V)/24k $\Omega$ .

AC Metering Specifications			
Description	Conditions	Parameter	Specification
AC Peak-Peak Meter	Low Band, VDC= 40-57V	Accuracy, 25Hz – 325Hz	-15%, +11%
		Accuracy, 50Hz – 300Hz	-7.5%, +11%
	High Band, VDC= 40-57V	Accuracy, 2.5KHz – 250KHz	-15%, +7%
		Accuracy, 20KHz – 250KHz	-6%, +7%
	Full Band, VDC= 40-57V	Accuracy, 50Hz – 250KHz	-7.5%, +8.5%
		Resolution	1mV
		Range	1Vp-p
All Bands, VDC= 40-57V	Input Impedance	0.05 $\mu\text{F}$	

Triggering Specifications			
Description	Conditions	Parameter	Specification
Edge & Event Triggers	All Modes	Range	0.25V - 59.5V
		Resolution	0.125 mV
		Accuracy (relative to DC Meter)	± 0.0625 mV
		Trig1 to Meter or Transient Latency	~ 50 µsec
		Event Trigger Latency	< 500 µsec
	Trigger Noise Immunity	Pre-Trigger Qualification Time (Voltage below Rising threshold or above Falling threshold)	1.5 msec
		Normal Mode Edge Noise Rejection	125 mV
		Noisy Mode Edge Noise Rejection	500 mV

Time Interval Metering Specifications			
Description	Conditions	Parameter	Specification
Time Interval Meter	Microsecond scale	Time Range	4 – 26200 µsec
		Time Resolution	1 µsec
		Time Accuracy	+ 2 µsec
		Min. Resolvable Time Interval	~ 4 µsec
	Millisecond scale	Time Range	2-6550 msec
		Time Resolution	0.1 msec
		Time Accuracy	+ 1 msec
		Min. Resolvable Time Interval	2 msec
	Second Scale	Time Range	0.1 – 16.1 sec
		Time Resolution	0.1 sec
		Time Accuracy	+ 0.05 sec
		Min. Resolvable Time Interval	0.1 sec
	Triggering & Noise Immunity	Start Trigger	Edge or Event
		Stop Trigger	Edge
		Normal Mode Edge Noise Rejection	125 mV
		Noisy Mode Edge Noise Rejection	500 mV

LED Indicators		
LED Label	Parameter	Description
DET	Detection Enabled	<b>ON:</b> Valid Detection Signature Connected (R= 19 to 26 KΩ, C= 0µF) AND Port Switch Connected <b>BLINKING:</b> Configured for LAN Termination. Long on-time blink for LINK UP, short on-time blink for UNLINKED. <b>OFF:</b> Invalid or no PD Signature AND configured as through.
PWR	PSE Power On	<b>ON:</b> Indicates Power-Up with Vport > 36 VDC (Regardless of Trigger State) <b>OFF:</b> Vport < 36 VDC
ARM	Trigger ARM	<b>ON:</b> Trigger 1 in the ARMED State <b>OFF:</b> Trigger 1 NOT in the ARMED State
AUX	Communications	<b>ON or BLINKING:</b> Indicates Communications to PSA Test Port

Programming and Control	
Description	Specification
Interface	Ethernet 10/100BaseT
Host Requirements	PC running Microsoft Windows NT, 2000, XP, Vista, or Linux PC (Fedora, SUSE)
Control Environment	Sifos PowerShell or PSA-Interactive
Recommended Network Latency:	< 5 msec



Physical and Environmental	
Description	Specification
Dimensions	4"W x 1. 5"H x 8.5"D
Weight	1.2 lbs
Power	100VAC-240VAC, 50-60 Hz, 5VDC, 700mA (External Power Module Included)
Ambient Operating Temperature	0°C to 50°C (≤ 42.75 Watt loading per port)
Storage Temperature	-20°C to 85°C
Operating Humidity	5% to 95% RH, Non-Condensing.

Certifications	
Description	Certifications
Emissions	FCC Part 15, Class A Meets EN55022 VCCI, AS/NZS 3548
Safety	CSA Listed (CSA22.2 No. 61010) Meets EN61010-1 CB Scheme IEC 61010-1
European Commission	Low Voltage Directive (73/23/EEC) Electromagnetic Compatibility Directive (89/336/EEC) CE Marking Directive (93/68/EEC)
<p>FCC Statement:</p> <p>This equipment has been tested and found to comply with the limits for a Class A digital device, pursuant to part 15 of the FCC Rules. These limits are designed to provide reasonable protection against harmful interference when the equipment is operated in a commercial environment. This equipment generates, uses, and can radiate radio frequency energy and, if not installed and used in accordance with the instructions, may cause harmful interference to radio communications. Operation of this equipment in a residential area is likely to cause harmful interference in which case the user will be required to correct the interference at their own expense.</p>	

## Ordering Information

**PSA-3002**, PowerSync Analyzer 3002 including PowerShell PSA and PSA Interactive Software

**PSA-LLPD**, LLDP Emulation and Analysis Feature for One PSA PSA-3002 Instrument

**PSA-CT**, PSE Conformance Test Suite for One PSA-3002 Instrument

**PSA-TS1**, PSE Automated Test Suite Tracking Service for One Year for One PSA-3002 Instrument

**PSA-TS2**, PSE Automated Test Suite Tracking Service for Two Years for One PSA-3002 Instrument

- Accessories Included:**
- Installation Guide & Configuration Chart
  - PowerSync Analyzer Reference Manual (Binder and CD)
  - Power Cord
  - Cross-Over Ethernet Cable
  - RS-232 Cable

Sifos Technologies, Inc.  
1061 East Street  
Tewksbury, MA 01876  
+1 (978) 640-4900  
www.sifos.com  
[sales@sifos.com](mailto:sales@sifos.com)

**Verification, Simplified.**