



CX180R

Return Path Monitoring System

All-in-One Return Path Solution

- Return path ingress monitoring
- UCD Monitoring
- Return path spectrum analysis
- Return path MER/BER measurement
- Return path sweep
- Return path balancing

Platform Highlights

- Low system entry cost
- Space efficient 1U rackmount with built-in matrix switch
- Factory calibration - eliminates unexpected insertion loss introduced by external matrix switches
- Flexible distributed architecture with VeSion system for easy expansion, increased reliability, and reduced system down time
- Secured IP connection for access from any location with Internet connection via web, VeSion mobile application for Android or iOS, or VeEX portable test sets
- Three independent test resources for non-blocking monitor scan and two on-demand tests.
- Interfaces with VeEX portable test sets to enable Sweep, Ingress and Digital Signal measurements for complete single person Return Path troubleshooting and maintenance

Key Features

- Frequency range analysis 4 to 245 MHz with CX180R-240M IGM hardware type; 4 to 85 MHz Frequency range with CX180R IGM*
- Adjustable RBW at 125 kHz, 330 kHz, 1 MHz that captures fast and low level transient ingress
- Fast spectrum analysis to capture bursty upstream cable modem signals and noise spikes
- Advanced QAM analysis supports QAM-16/64/128 upstream signal formats
- Return Path QAM measures MER, pre/post BER analysis and display of Constellation diagram
- Return Path Sweep and Balancing with VeEX portable test sets
- Expandable Server software for archiving return path measurements for post review and analysis
- User programmable alarm thresholds to generate alarm tickets by email, SMS, SNMP and Syslog

**Note: Standard frequency range is 4 to 65 MHz and can be extended to 85 MHz with software options.*

Introduction

The VeSion Return system monitors the return path for noise, UCD and ingress that interfere with DOCSIS communications. With DOCSIS 3.0/3.1 deployments, higher order upstream QAM modulation and channel bonding are more vulnerable to ingress and should be monitored continuously to ensure peak performance.

The CX180R sets new standards for form factor and performance. The space saving 1U rack mount unit integrates multiple DSP based test resources dedicated to 10 nodes in each system. Each CX180R unit supports three different test modes simultaneously and independently. In ingress scan mode, fast transients can be identified at a scan rate of up to 250ms per node. In spectrum analyzer mode, on demand RF signal analysis using optimal programmable RBW and dwell time can be performed.

QAM Analysis, Sweep and Balancing tests in the Return Path by a single technician is possible using VeEX handheld test units. Up to two technicians can interface with the CX180R at any given time, maximizing productivity. Return path QAM analysis is becoming critical in DOCSIS 3.0/3.1 deployments because QAM-64 is more susceptible to noise and other network impairments compared to lower modulation schemes, for example, QPSK or QAM16. When paired with a VeEX handheld tester equipped with USG+FEC option that generates a QAM64 or QAM128 signal, operators can easily assess and benchmark MER and BER performance to qualify the network for carrying higher order modulations thus identifying the network problems prior to service activation. Return path sweep and return path balancing are two convenient options allowing operators to identify frequency dependant problems, for example, balancing of an amplifier with one person operation.

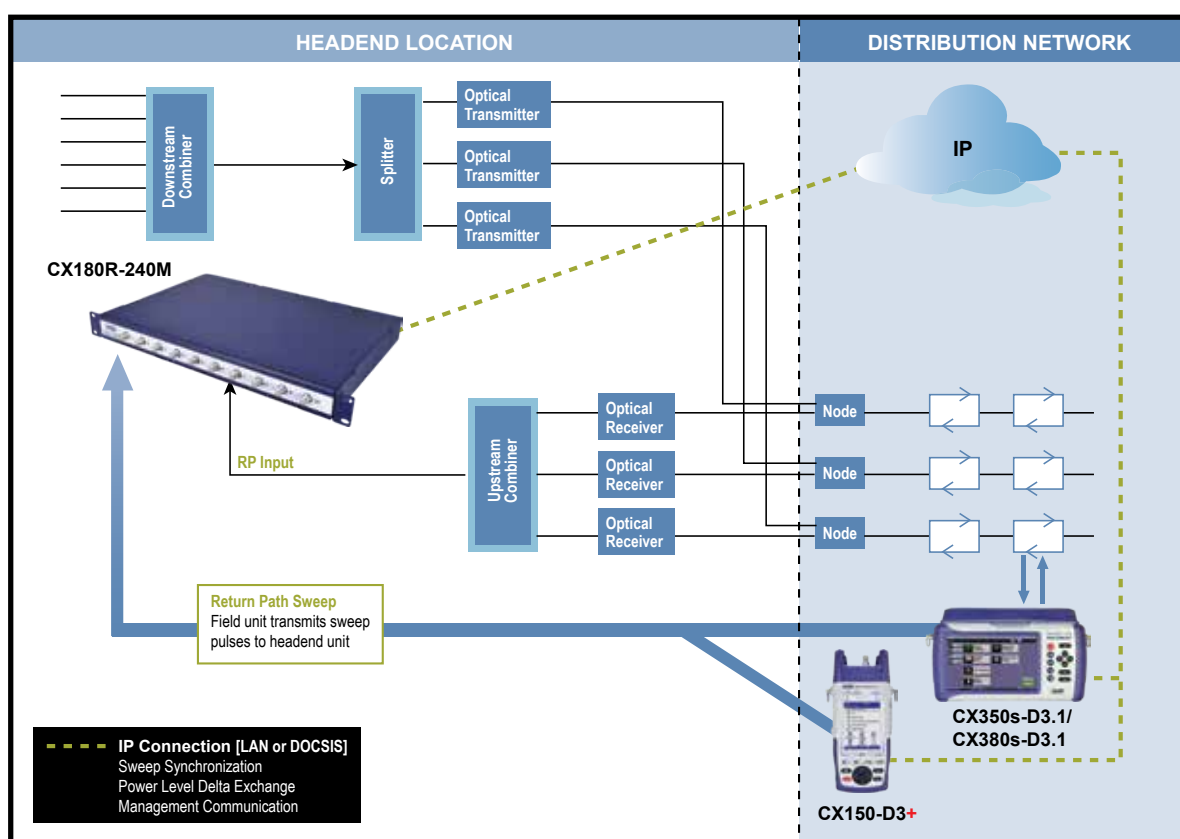

Under the VeSion system, the CX180R uses a distributed architecture that provides the most cost-effective solution, yet allows maximum flexibility for future expansion and maintenance. The 1U rackmount unit can easily fit into a mini-headend where the number of nodes is typically limited. An expanding headend can start with a few CX180R probes and more can be added as demand dictates. Therefore, there is no large upfront investment needed for a bulky or expensive card nor an expensive test head that can only monitor one node at a time.

Using web or mobile applications, maintenance staff can access the VeSion system to view historical monitoring results, gain access to on-demand spectrum analysis or return path QAM analysis anywhere Internet connection is available. Field technicians, equipped with VeEX portable test sets, and Remote View option, can view ingress results and perform spectrum analysis at a remote location without needing a laptop computer.

Together with VeSion, the system can be tailored depending on the specific requirement of the Service Provider. Graphical alarms, user defined threshold settings, alarm generation by emails, SNMP, Syslog or SMS, trouble tickets management and data logging are but a few examples of key features supported by the system.

The CX180R has a built-in, dual power switching matrix to ensure continuous operation if the main power supply fails.

Features

Return Path Spectrum Analysis

Advanced DSP technology captures fast transient signals with millisecond resolution. Dynamic changes in system noise level and short bursty pulses typical of Cable Modem upstream transmission can easily be captured to identify potential problems in operational upstream DOCSIS channels.

Each CX180R can perform spectrum analysis on two nodes simultaneously. Spectrum analysis can be controlled by mobile applications, web, or by a VeEX handheld unit via Internet connection in the field.

Return Spectrum - VeSion



Return Spectrum - Mobile Application



Return Path QAM Analysis

To ensure the return path is properly configured and provisioned for QAM64 or QAM128 upstream transmission, the CX180R interfaces with a remote VeEX handheld unit to evaluate the quality of return path QAM signal. Parameters, including QAM level, Pre-FEC, Post-FEC, MER, Errored seconds, and Severely errored seconds are supported. Constellation diagrams allow experienced technical staff to identify problems caused by laser clipping or jitter. A CX180R working in tandem with a VeEX handheld unit via an Internet connection enables one person troubleshooting and measurement, thus reducing truck rolls and associated manpower requirements.

Each CX180R unit can perform two separate QAM analyses simultaneously.



Ingress Monitoring

Dedicated test resources scan each node ensuring that abnormal signal conditions be detected and identified quickly. 125 kHz RBW filter reveals low-level transient noise that 1 MHz RBW cannot resolve.

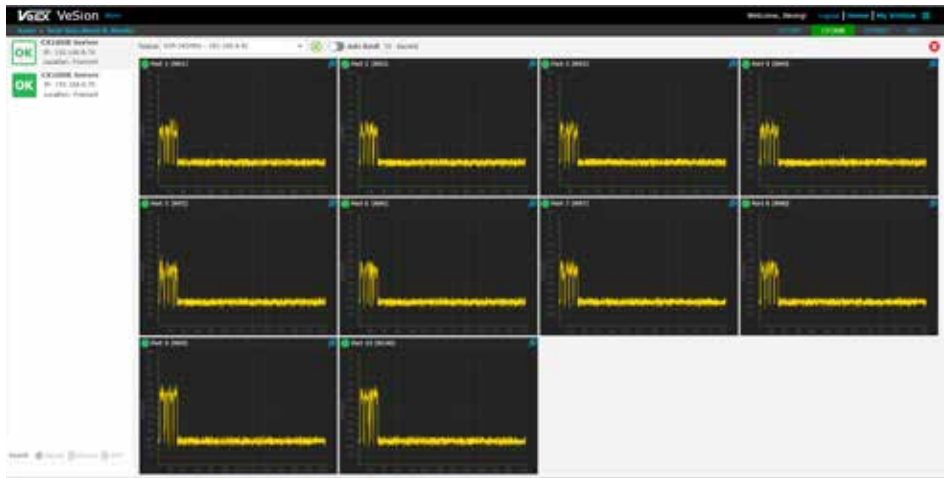

Data Logging and Alarm Reporting

Alarm types, test thresholds, and reporting method can be easily defined by the system engineer in VeSion. Trouble tickets and status updates can be viewed remotely and updated by maintenance personnel using web connection to the VeSion system.

Measured data is stored in the VeSion system database for an extended period of up to 200 days, depending on the capacity of hard disk which can be configured by the system administrator. Archived data can be recalled and correlated with current alarm condition in live play back mode.

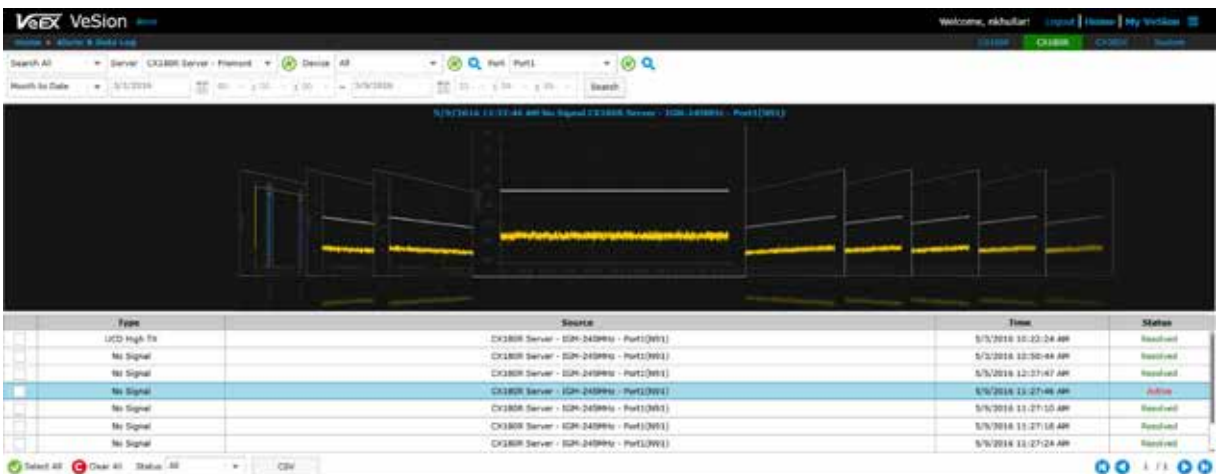

Features

Return Path Sweep

The CX180R incorporates a Sweep receiver which measures sweep tones being generated by a VeEX handheld unit fitted with USG+FEC and return path sweep options.

The sweep system communicates non-intrusive user defined sweep tables and measured test data to a remote VeEX field test set over the Internet, freeing up valuable downstream bandwidth which is used by telemetry systems found in competitive sweep systems. Up to two remote field test sets are able to connect to the CX180R in the VeSion system simultaneously to perform upstream sweep measurements.



Remote View

Return path troubleshooting and testing is simplified with the Remote View feature. Using a wired or wireless Internet connection, a technician operating a VeEX handheld test set in the field is able to access and view real time measurements being performed by the CX180R in the VeSion system located in the Node or Headend. Developed specifically for dual ended test applications, evaluating MER, BER and Constellation and related upstream parameters is extremely fast and easy. Real-time ingress measurements made by the CX180R spectrum analyzer can also be viewed Quasi real-time on the field test unit making it a truly unique solution for upstream testing and characterization.

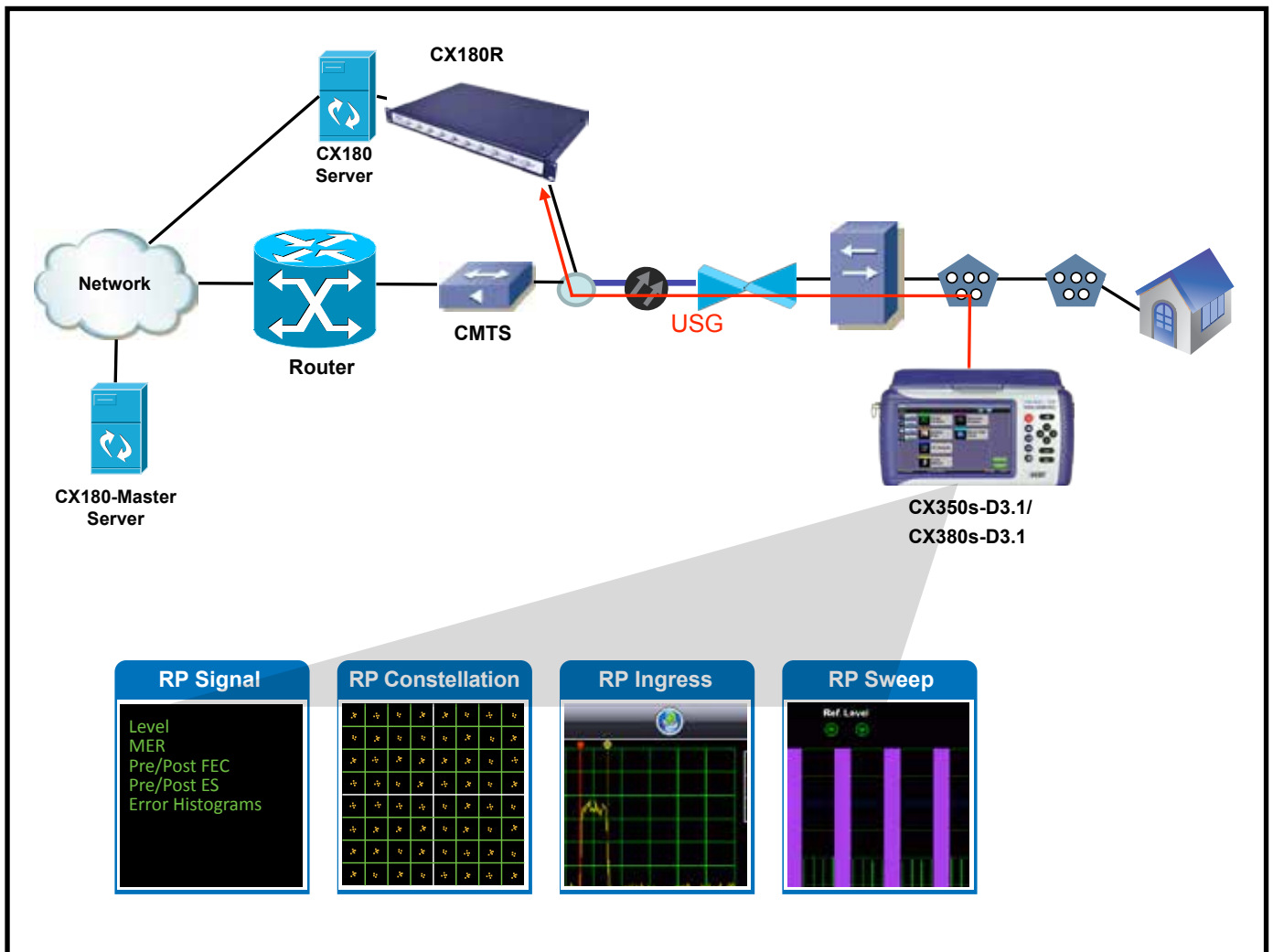
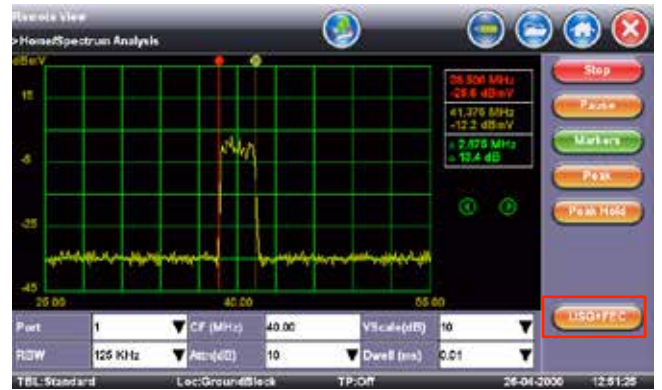

Cloud-Based One System Platform

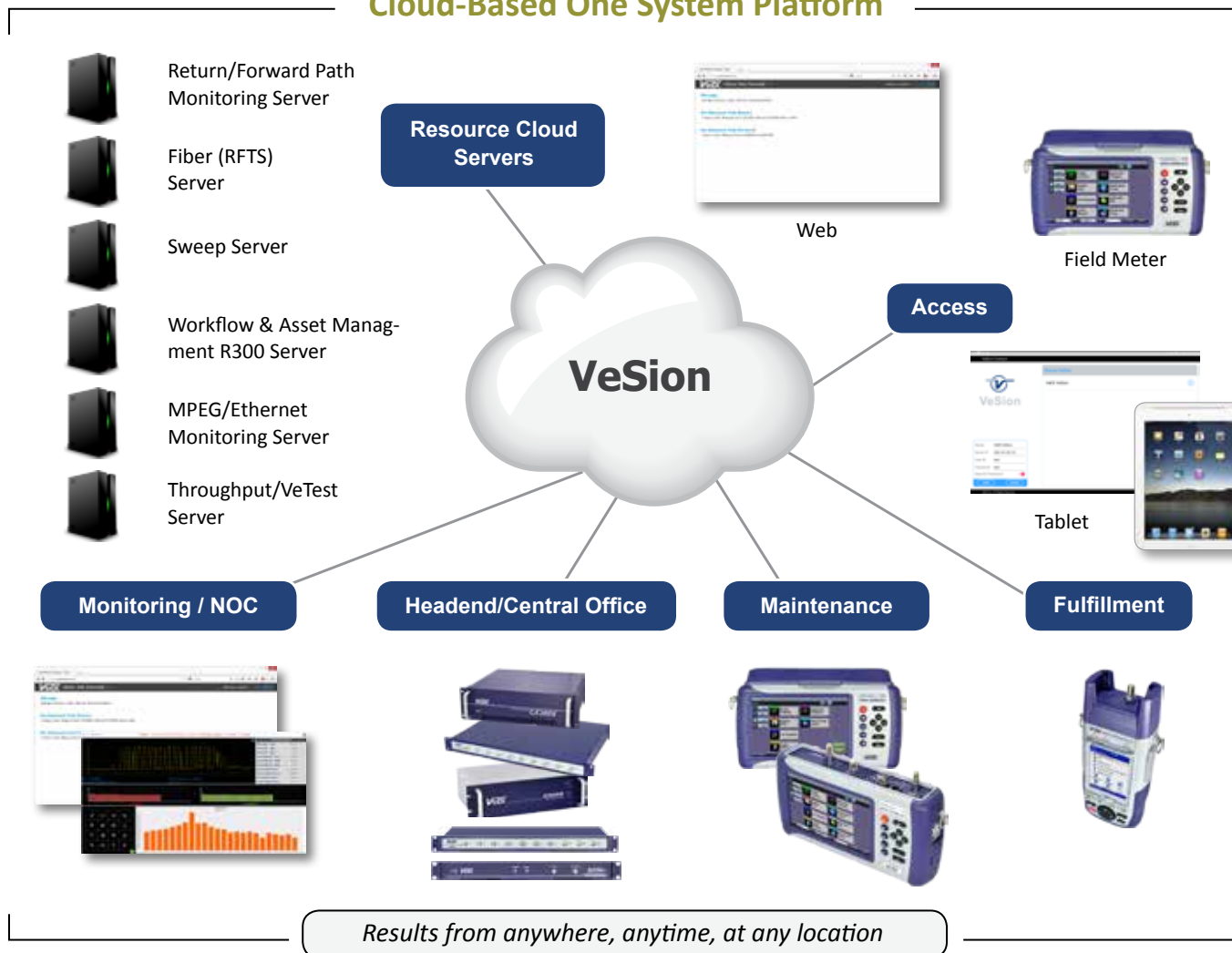

Specifications

Return Path Ingress Scan

Frequency range

- 4 to 245 MHz (CX180R 240M IGM)
- 4 to 85 MHz (CX180R IGM)

Dynamic range: 50 dB

Resolution Bandwidth: 125 kHz, 330 kHz, 1 MHz

Attenuation range: 0 to 50 dB, 10 dB/step

Range with attenuation: -45 dBmV to +60 dBmV

Return Path Spectrum Analysis

Frequency range: 4 to 245 MHz

Dynamic range: 50 dB

Resolution Bandwidth: 125 kHz, 330 kHz, 1 MHz

Attenuation range: 0 to 50 dB, 10 dB/step

Range with attenuation: -45 dBmV to +55 dBmV

Dwell time: 0.01 ms to 2.56 ms, adjustable

Minimum noise burst measureable: <1 microsecond

Return Path QAM-16/64/128 Analysis

Frequency range: 5 to 245 MHz

QAM Locking range: -10 to +50 dBm

Supports Annex A, B, and C

QAM level, MER, pre/post BER, Errored seconds, Severely Errored seconds

Constellation diagram

Requires CX field meter with USG+FEC option

Hardware Options

CX180R-240M 10-4 with frequency range 4 to 245 MHz.

Rear port for expansion to advanced CX380X probe for burst demodulation and PNM.

CX180R-IGM 10-3 with frequency range 4 to 65 MHz. With

software option, expand frequency range up-to 85 MHz.

CX180R-IGM 10-4 with frequency range 4 to 65 MHz. With

software option, expand frequency range upto 85 MHz
Rear port for expansion to advanced CX380X probe for burst demodulation and PNM.

General Specifications

Size	432 x 299 x 38 mm (W x D x H) 17 x 11.75 x 1.49 in
Weight	Less than 3.2 kg (less than 7 lb)
AC Adaptor	Input: 100-240 VAC, 50-60 Hz Output: 15VDC, 3.5A
Operating Temperature	-10°C to 50°C (14°F to 122°F)
Storage Temperature	-20°C to 70°C (-4°F to 158°F)
Humidity	5% to 95% non-condensing



VeEX Inc.
2827 Lakeview Court
Fremont, CA 94538 USA
Tel: +1.510.651.0500
Fax: +1.510.651.0505
www.veexinc.com
customercare@veexinc.com

© 2017 VeEX Inc. All rights reserved.
VeEX is a registered trademark of VeEX Inc. The information contained in this document is accurate. However, we reserve the right to change any contents at any time without notice. We accept no responsibility for any errors or omissions. In case of discrepancy, the web version takes precedence over any printed literature.
D05-00-010P C00 2017/08