

INSITE Free

An E-field narrow band measurement system to define safety perimeter or perform site certification



- Compatible with most spectrum analyzers available on the market
- Tri-axial probes with excellent isotropic measurement
- Additional option for ANFR protocols

Main features

Measurement capabilities

- Performs in situ spot measurements

User profile

- Regulation agencies, certification offices, municipalities, broadcast, PMR and mobile phone operators, installers, research laboratories, administrative bodies and more

Frequency bands

- 100 KHz to 6 GHz

Related recommendations

- EN50383, EN 50492 and IEC 62232

Compatible with most spectrum analyzers

- AEROFLEX: 3254, MT8220A, MT8222A, 9101, 9102, S332D, S362E
- ANRITSU: MS2661B, MS2665C, MS2711A, MS2711D, MS2711E, MS2712E, MS2713E, MS2720T, MS2721B, MS2724B, MS2724C, MS2726C, MT8212B,
- Rohde & Schwarz: FSH3, FSH4, FSH6, FSH8, FSL6, FSL18, FSP, FSV3, FSV7, ZVL3
- Keysight: E7495B, ESA series, 856xEC series, N9912A

System Configuration

Software

- INSITE Free on CD Rom with dongle key
- INSITE Free/ANFR on CD Rom with dongle key

Equipment

- 100 KHz to 3 GHz probe
- 700 MHz to 6 GHz probe
- Spectrum analyzer
- Switch box (with battery charger)
- Probe holder
- Wooden tripod

Accessories

- Cables

Services

- Initial probe and cable calibration
- Additional calibration
- Training
- Extended warranty

■ Included □ Optional ○ Required

INSITE Free is composed of a probe connected to a switch/amplification box. The system also requires a spectrum analyzer. These elements can be operated either manually or remotely through INSITE Free software. The software enables the user to define measurement scenarios, analyze measurements, review the results graphically and automatically generate reports in Excel format. The switch enables successive selections of the three measurement axes to obtain an isotropic result without changing the position of the probe. Equipped with an amplifier, the switch also improves the sensitivity of the system over the 100 KHz to 30 MHz frequency bands.

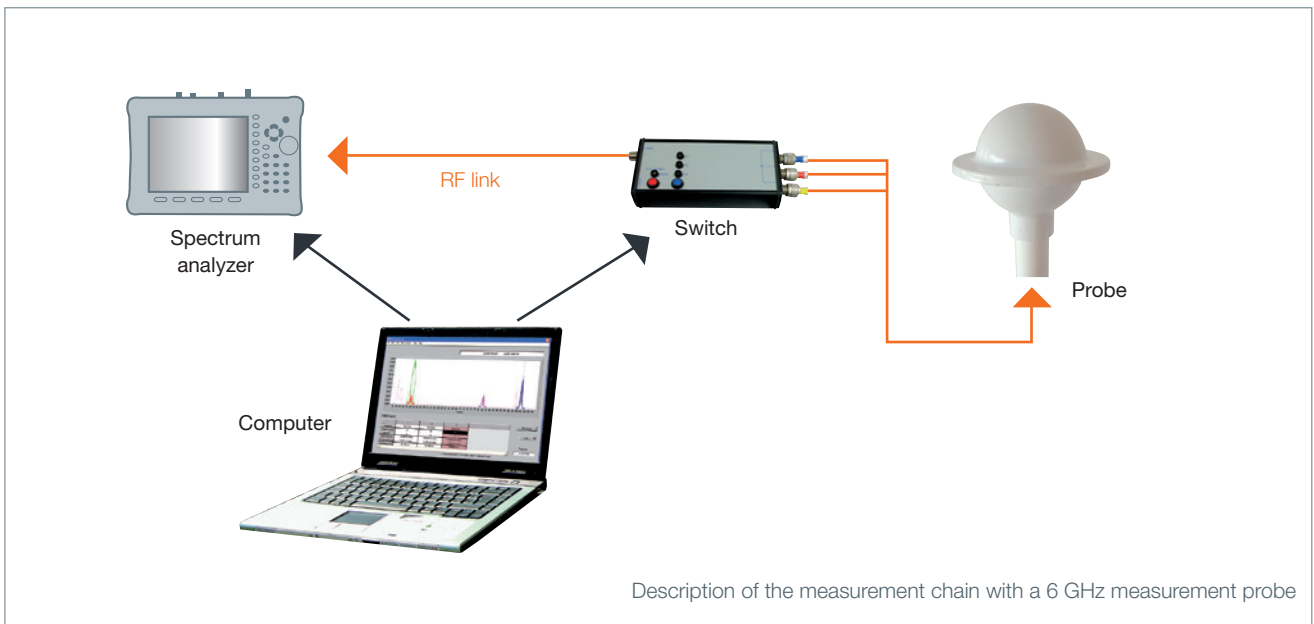

Measurement scenarios can be defined by the user to fit specific requirements

- ❶ INSITE Free SW is a flexible tool that can be configured by the user to perform measurements and generate reports according to specific measurement protocols, in particular those recommended by ECC.
- ❷ In addition, INSITE Free/ANFR SW follows the protocol of the French National Agency of Frequencies (ANFR) step by step.

STEP 1: Choose hardware configuration

In this first phase, the user programs the measurement session according to his own hardware configuration: spectrum analyzer, GPS, probe, cable, UMTS scanner and

switch. For this purpose, the probes, cable and switch calibration files are selected and loaded. A selection of several probes is possible. INSITE Free works with all of the most frequently used spectrum analyzers.

STEP 2: Define measurement scenario

Once the hardware has been configured, the user can program the measurement scenarios:

- Choose frequency bands to be measured from a list or create user-defined bands
- Define the channels or specific carriers
- Define channel width
- Choose attenuation mode
- Choose analysis mode (CW, TDMA, W-CDMA, LTE)
- Choose automatic or manual definition of RBW/VBW

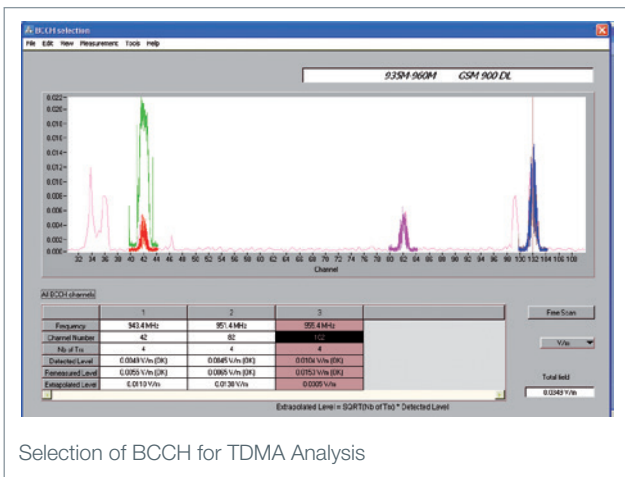

STEP 3: Perform measurement analysis.

The data collected for each band is presented on the main window of the software. Measurements corresponding to each of the three axes can be displayed in order to check the polarisation of the electric field.

Depending on the characteristics of the spectrum analyzer, the user can repeat the following analysis modes:

- CW Analysis: selection of peaks according to predefined threshold
- TDMA analysis: extrapolation of BCCH value
- W-CDMA analysis: UMTS decoding (measurement and extrapolation of the CPICH value)
- LTE analysis : extrapolation of NPBCH value

The user can re-launch measurements using specific detection modes (positive peak, negative peak, sample...) and measurement modes (Max. hold, Min. hold, and average) available with the spectrum analyzer.

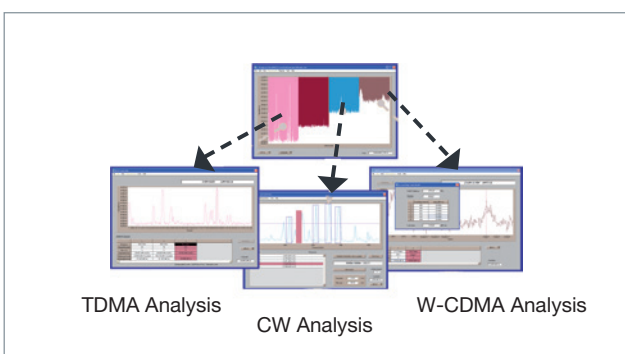

STEP 4: Visualize results

The results can be visualized with the following functions:

- Full scan or per frequency band
- Zoom in with peak identification threshold
- 3 types of scales for a better high and low band visualization
- Quick view of element's properties

Sessions are saved in XML and results can be exported to Excel. The results can be compared to the reference levels given by specific guidelines. Two guidelines are available by default:

- ICNIRP
- Safety Code 6

(Other reference levels can be added upon request).

High performance isotropic probes to cover the 100 KHz to 6 GHz frequency ranges

Two probes are available: from 100 KHz to 3 GHz and from 700 MHz to 6 GHz. Both probes are made of three orthogonal monopoles. The patented shape of each monopole optimizes the functioning and isotropy of the probe over the entire frequency range.

MECHANICAL CHARACTERISTICS / 100 KHz - 3 GHz PROBE

Dimension (without cable)	406 mm
Weight	980 gr
RF cable length	2 m
Connector	3N
Protection	IP 44
Conditions for use (temperature, humidity)	-10 to 50°C, 85 % humidity

ELECTRICAL CHARACTERISTICS / 100 KHz - 3 GHz PROBE

Sensitivity at 900 MHz (Given for a spectrum analyzer sensitivity of -90 dBm) (Cable loss taken into account)	1 mV/m
Max. E-field/900 MHz	200 V/m
Isotropy at 900 MHz	± 1 dB
Isotropy at 1800 MHz	± 1,7 dB

100 KHz - 3 GHz probe antenna factor

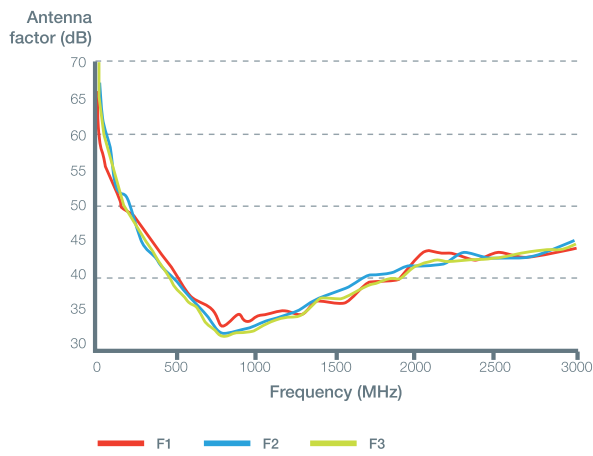

Axial Isotropy at 900 MHz

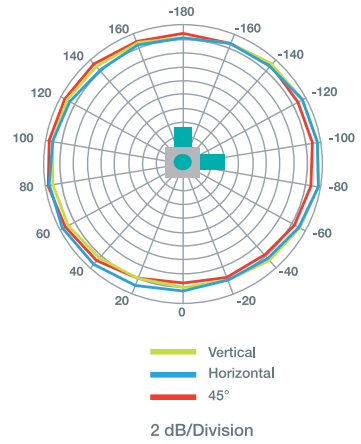

100 KHz - 3 GHz probe sensitivity without amplifier

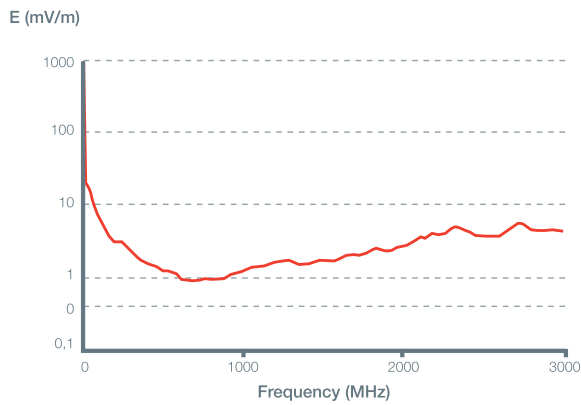

100 KHz - 30 MHz probe sensitivity with amplifier

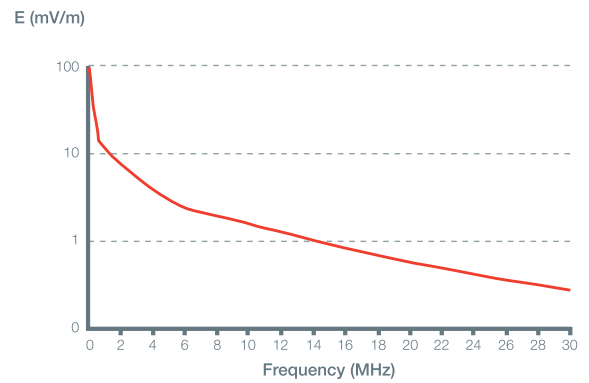

100 KHz - 3 GHz Axial Isotropy with horizontal polarization

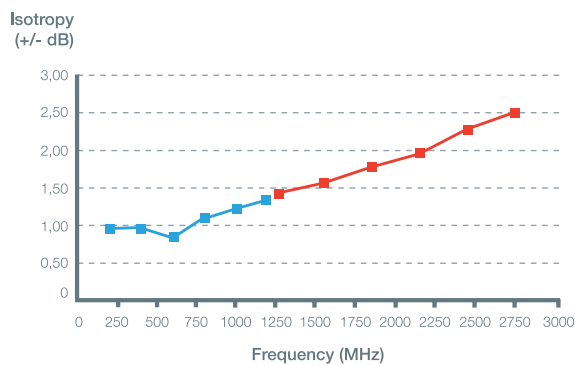

100 KHz - 3 GHz Axial Isotropy with vertical polarization

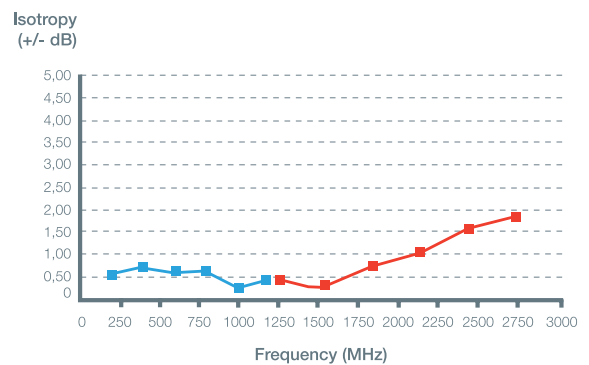

MECHANICAL CHARACTERISTICS / 700 MHz - 6 GHz PROBE

Dimension (without cable)	70 mm
Weight	800 gr
RF cable length	2 m
Connector	3N
Protection	IP 44
Conditions for use (temperature, humidity)	10 to 50°C, 85 % humidity

ELECTRICAL CHARACTERISTICS / 700 MHz - 6 GHz PROBE

Sensitivity at 900 MHz (Given for a spectrum analyzer sensitivity of -90 dBm) (Cable loss taken into account)	3,5 mV/m
Max. E-field/900 MHz	200 V/m
Isotropy at 900 MHz	+/- 1,6 dB
Isotropy at 1800 MHz	+/- 2,5 dB

700 MHz - 6 GHz probe antenna factor

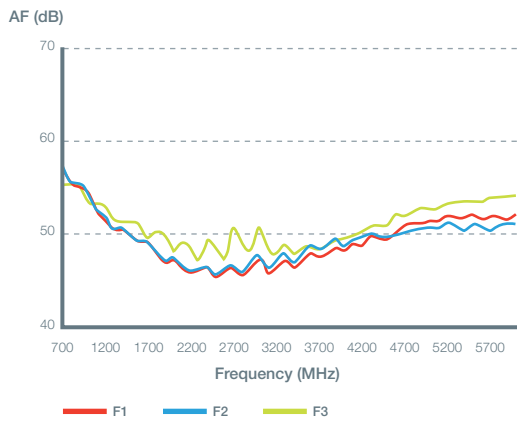

Axial Isotropy 3.6 GHz

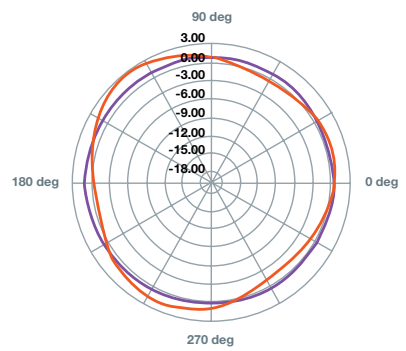

700 MHz - 6 GHz probe sensitivity

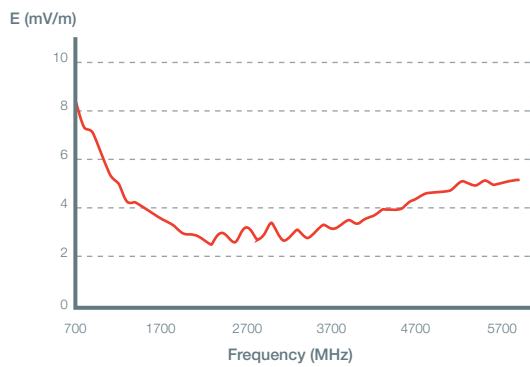

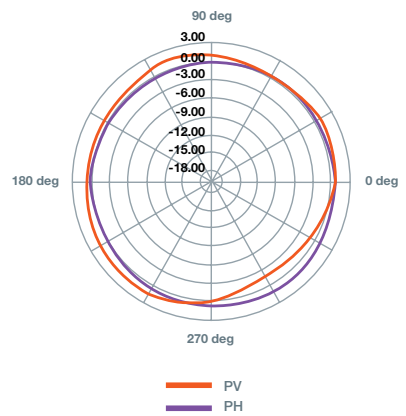

Axial Isotropy 5.6 GHz



Perform isotropic measurements without changing the position of the probe

INSITE Free System performs a measurement for each axis and all predefined bands. The power value measured on each axis is then converted into field value.

FOR EACH BAND

One scan for each axis	X 	Y 	Z 
Conversion in field value	$[E] \text{ (dB V/m)} = P_{\text{mes}} \text{ (dBm)} - 13 + \text{loss} + \text{AF} \text{ (dB m-1)}$ AF: Antenna Factor loss: cable loss, switch loss		
Isotropic value calculation	$[E_{\text{total}}] \text{ (V/m)} = ([E_x]^2 \text{ (V/m)} + [E_y]^2 \text{ (V/m)} + [E_z]^2 \text{ (V/m)})^{1/2}$		

SWITCH BOX CHARACTERISTICS

Dimensions	100 mm x 200 mm x 50 mm	Frequency range	100 KHz – 6 GHz
Battery life	4 hours	Immunity	200 V/m
Protection	IP55	Frequency range amplifier	100 KHz – 30 MHz
N connections	Output: 1 female Input: 3 female	Max power input for amplifier	-30 dBm
Interface	USB	Amplifier gain	32 dB
Working conditions	-10 to 50°C, 85% humidity	Intermodulation	-30 dB @ -50 dBm -40 dB @ -60 dBm

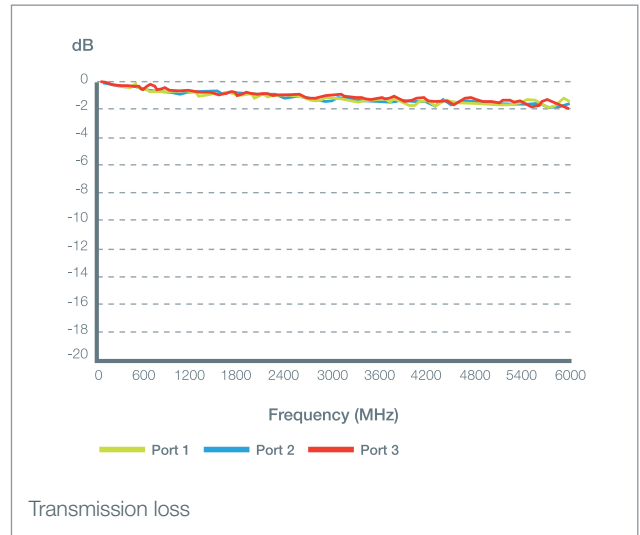
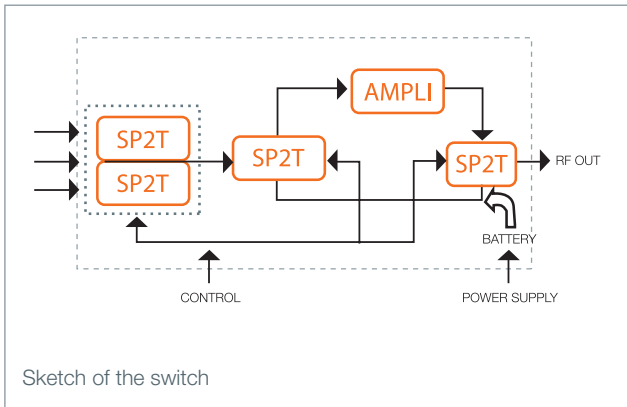

Antenna factor with or without amplifier

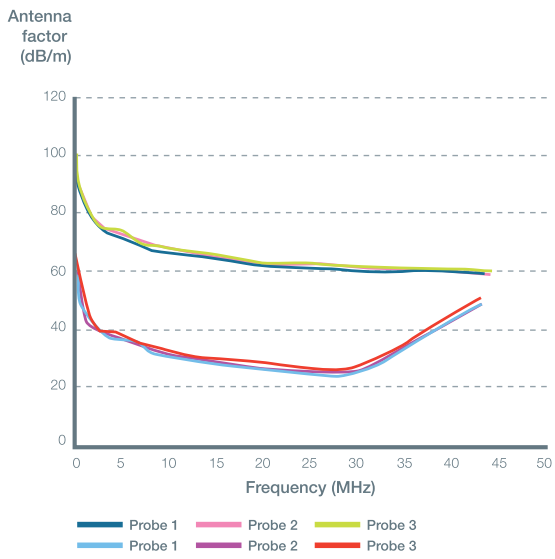

Amplifier gain

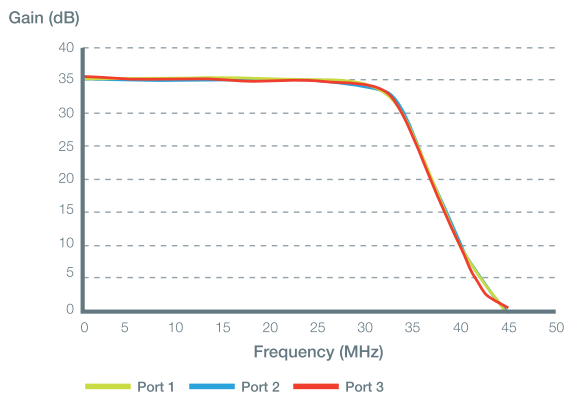

HARDWARE REQUIREMENTS

Computer	Processor 2 GHz
Cable link*	3 USB Ports
Operating system	XP / WIN7 / WIN8 / WIN10
Memory	2 GB RAM
Free space	500 MB free space on hard disc

* Serial port, USB, Ethernet or GPIB may be necessary depending on the analyzer

About Microwave Vision Group (MVG)

Since its creation in 1986, The Microwave Vision Group (MVG) has developed a unique expertise in the visualization of electromagnetic waves. These waves are at the heart of our daily lives: Smartphones, computers, tablets, cars, trains, planes - none of these devices and vehicles would work without them. Year after year, the Group develops and markets systems that allow for the visualization of these waves, while evaluating the characteristics of antennas, and helping speed up the development of products using microwave frequencies.

The Group's mission is to extend this unique technology to all sectors where it will bring strong added value. Since 2012, MVG is structured around 3 departments: AMS (Antenna Measurement Systems), EMC (Electro-Magnetic Compatibility), EIC (Environmental & Industrial Control).

MVG is present in 10 countries, and generates 90% of sales from exports. The Group has over 350 employees and a loyal customer base of international companies.

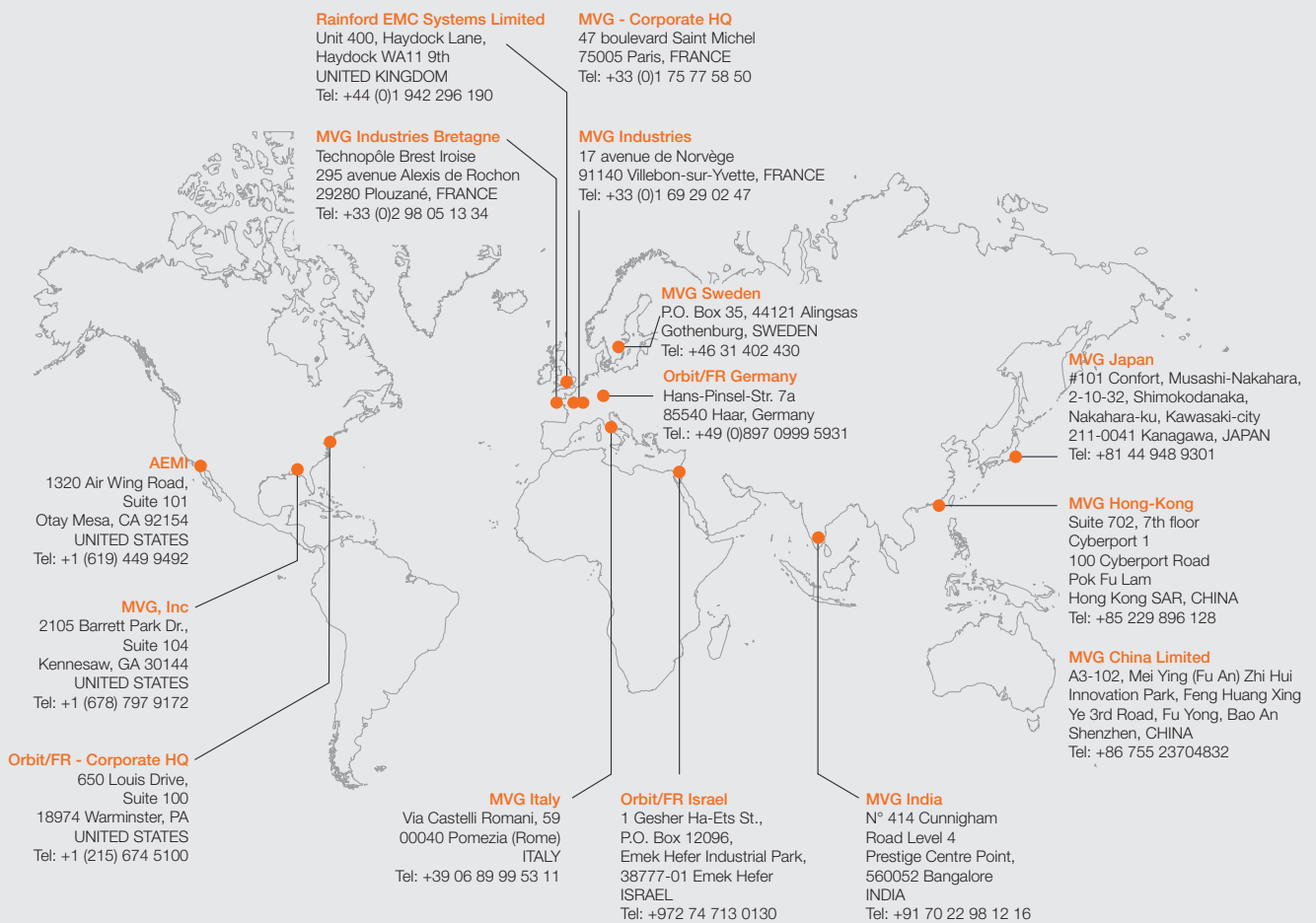

© MVG 2018 - Graphic design: www.atelemaupoux.com, pictures: all rights reserved. Product specifications and descriptions in this document are subject to change without notice. Actual products may differ in appearance from images shown.



Contact your local sales representative
for more information



www.mvg-world.com/rfsafety
salesteam@mvg-world.com