

RXT-3400

Advanced Multi-Service Test Module

16G Fibre Channel
12G CPRI
11G OTN
10G Ethernet
10G SDH/SONET
PDH/DSn



for RXT-1200 Modular Test Platform



The RXT-3400 add-on module for the versatile RXT test platform offers state-of-the-art support for Access, Metro, Core, Transport, Carrier Ethernet, Backhaul, Fronthaul and SAN Technologies up to 16GFC. VeEX® RXT is the industry's most flexible, compact, complete and future-proof hand-held test solution, from 64k to 400GE, including Fiber Optics and WDM.

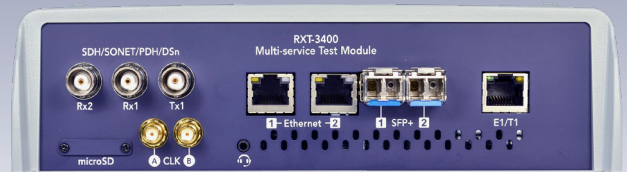

Module Highlights

- Flexible, all-in-one multi-service test solution, from 64 kbps to 14 Gbps (can be combined with 400G, 100G/40G, OTDR, and OSA modules)
- Offers two fully independent test port groups

Test Interfaces (per module)		
Ports	Technology	Rates
2 SFP+/SFP	Ethernet Fibre Channel OTN SDH SONET CPRI IEEE® C37.94	10GBase-X, 1000Base-X, 100Base-FX, 10GBase-T, 5G Base-T, 2.5GBase-T 16G, 10G, 8G, 4G, 2G, 1G FC OTU2e, OTU1e, OTU2, OTU1 STM64/16/4/1/0, OC192/48/12/3/1 12.168G down to 614.4M 64k to 768k
2 RJ45	Ethernet	1000/100/10Base-T
3 BNC ²	SDH/SONET PDH/DSn	STM1/0, STS3/1 E4, E3, E2, E1, T3
1 RJ48 ¹	PDH/DSn	E1, T1, 64K Codirectional
2 SMA	Clock (Ext.)	1PPS, 1.544/2.048/10 MHz, 2.048 Mbps, 1.544 Mbps

¹Balanced ports available in RJ48 or Bantam connector.

²Tx1, Rx1, and Rx2. Rx2 port may be available for monitoring applications.

Fibre Channel

- Storage Area Networks (SAN) testing up to 16G FC
- BERT, Throughput, and RFC2544 test
- RFC2544: Throughput, latency, frame loss, back to back tests
- In-service monitor, capture and protocol decode
- Layer 1 and layer 2 loopbacks

Ethernet

- RFC2544 Throughput, latency, frame loss and back to back tests
- V-SAM test suite compliant with ITU-T Y.1564 standard
- IEEE 802.3ah, ITU-T Y.1731, IEEE 802.1ag, MPLS-TP OAM support
- Q in Q (VLAN stacking), MPLS, MPLS-TP, PBB support
- RFC6349 V-PERF TCP/UDP test suite
- Layer 2 Control Protocol Transparency test
- In-service monitoring with packet capture and on-screen protocol decode
- One way latency with optional built-in GNSS receiver
- Fully integrated solution for synchronized packet networks
- Supports IEEE 1588v2/PTP and SyncE/ITU-T G.8261 standards
- Master Clock and Slave clock emulation
- IEEE 1588v2/PTP protocol monitor & decode, and PDV analysis
- Wander measurement and MTIE/TDEV analysis
- ESMC SSM generation, monitoring, and decoding
- VoIP and IPTV testing

CPRI Testing

- Common Public Radio Interface standard (CPRI) Layer 2 tests (REC/BBU and RE/RRH emulation)
- BER testing with PRBS stress patterns
- Latency measurements

OTN/SDH/SONET/PDH/DSn

- Advanced flexible OTN, SDH/SONET, PDH/DSn test payload map/mux, including EoOTN (ODU2e, ODU0 and ODUflex)
- Overhead Monitoring and Byte decoding
- Protection Switching and Service Disruption Time (SDT)
- Round Trip Delay on all interfaces and payload mappings
- Tandem Connection Monitoring
- Jitter and Wander (E1, E3, DS1, DS3, STM-10, OC-3)
- Pulse Mask Analysis at E1, E3 and DS1, DS3 rates

Ethernet Key Features

RFC2544 Compliance Testing

Performs the RFC2544 automated test suite at all recommended frame sizes as well as user configurable frame sizes and up to full line rate. The test suite can be performed with the far end test partner in loopback mode or peer-to-peer mode - the latter allowing for symmetrical/asymmetrical testing. Thresholds may be configured for accurate SLA assurance and verification. The automated tests supported are throughput, latency, frame loss, and back-to-back frames.

In Advanced SLA Mode this feature combines the powerful multiservice throughput test capabilities with the RFC2544 industry test suite for SLA verification. Using this test function, service providers are able to verify SLAs while end-to-end QoS is assessed properly. By configuring one primary test stream and up to seven background streams each with independent frame size, bandwidth, and more importantly QoS levels, simulating different service applications is now realized. The Advanced RFC2544 SLA mode provides detailed visibility of the test parameters for each of the traffic streams being measured, providing an efficient in-depth qualification in a fast and automated way.

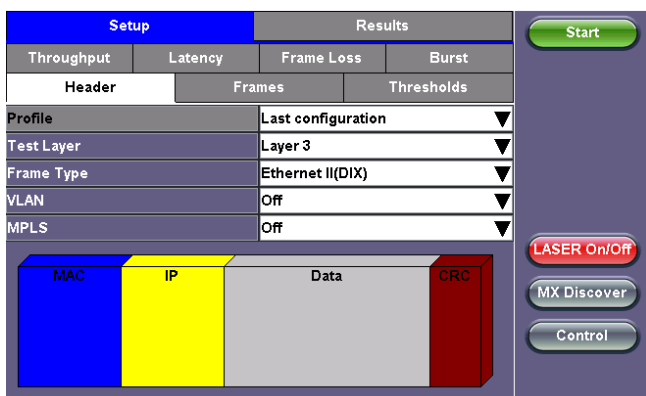

Multiple Streams Generation - Throughput

Up to ten traffic streams can be independently configured with CoS (VLAN priority) and QoS (TOS/DSCP) prioritization. This traffic feature simulates multiple service conditions (e.g. Triple Play), and facilitates end-to-end QoS performance verification. The multiple stream throughput tests may be performed with a second test unit at the far end in Smart Loop mode or Peer-to-Peer mode.

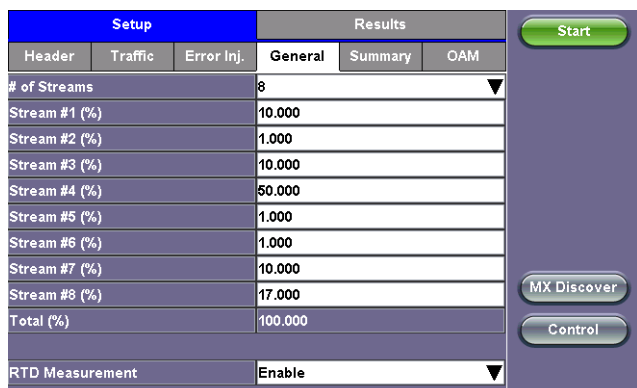

BERT

Layer 1 unframed and framed, 2, 3, and Layer 4 BER testing are supported. The BER test can be configured to use regular PRBS test patterns, or user defined test patterns to simulate various conditions.

Protocol Support

With intuitive graphical based user interface, users can fully customize test traffic at the Layer 2 (MAC header), Layer 3 (IPv4 and IPv6 headers) and Layer 4 (TCP,UDP). The test set also offers a complete tool set of advanced network protocols.

Q-in-Q (VLAN stacking)

VLAN stacking, also known as Q-in-Q, makes a provision for carrier/service provider assigned VLANs (SP-VLAN), but also retains customer traffic's VLAN (CE-VLAN). Up to three layers of VLAN tagging supported with configurable VLAN ID, Priority, and VLAN type.

Multiprotocol Label Switching (MPLS)

MPLS technology allows for a more efficient routing of Ethernet/IP packets via the use of MPLS routers in the network. MPLS labels reside between the MAC (Layer 2) and IP layers (Layer 3). Up to three MPLS tags can be configured in the traffic stream with customizable Label, CoS, and TTL fields.

Provider Backbone Bridging (PBB)

Also known as MAC-in-MAC, PBB (802.1ah) provides a trunking mechanism that adds resiliency and configurable performance levels in the provider backbone network. PBB encapsulation is available for all Ethernet tests with all PBB fields configurable.

Multiprotocol Label Switching Transport Profile (MPLS-TP)

MPLS-TP, a Layer 2 packet-based transport mechanism, is gaining momentum as a transport of choice for access and aggregation networks requiring a technology that combines the operational simplicity of packet switched networks with the operations, administration and maintenance (OAM) tools and fault resiliency capabilities of circuit switched networks. Fully configurable MPLS-TP header fields including LSP and Pseudowire.

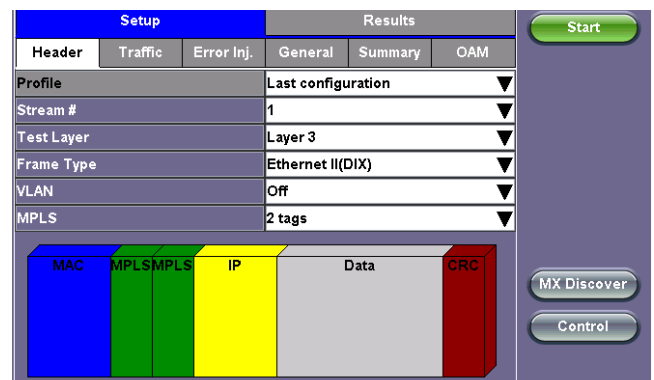

Y.1564 V-SAM Test

VeEX's V-SAM test suite is fully compliant with ITU-T Y.1564 and offers an efficient method to qualify and troubleshoot Ethernet Services. V-SAM addresses some of RCF2544 limitations by testing multiple services at once and providing simultaneous measurements of key SLA parameters.

With the Service Configuration test, services running on the same line are tested one by one to verify the correct service profile provisioning. With the Service Performance test, the services running on the same line are tested simultaneously over an extended period of time, to verify network robustness.

This test suite was designed with the end user in mind and allows for quick provisioning, execution and analysis of the test results, even without prior detailed knowledge of the standard.

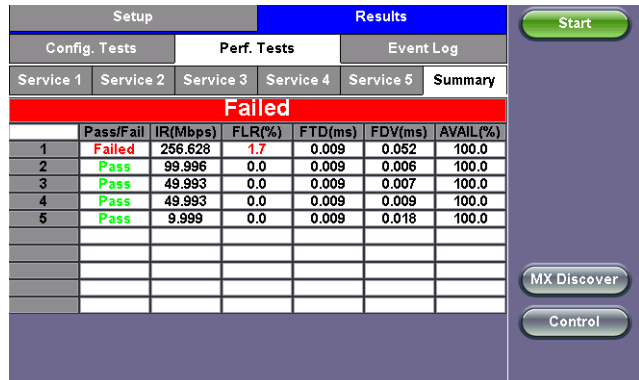
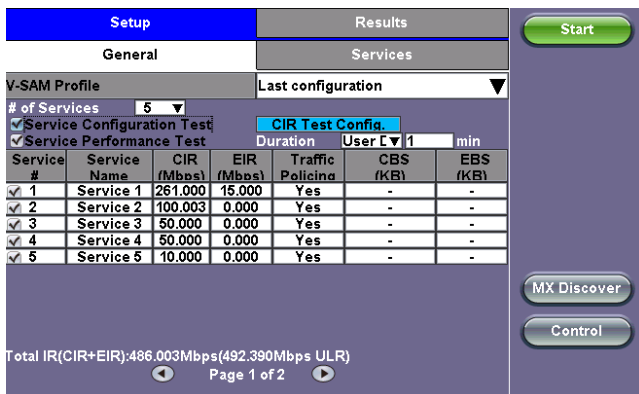

Ethernet OAM Features

The tester offers a complete tool set for Link Level (IEEE 802.3ah) and Service Level (IEEE 802.1ag/ ITU- Y.1731) OAM for monitoring and maintaining carrier grade Ethernet services as well as OAM support for MPLS-TP per ITU-T G.8113.1 including G-ACH and GAL labels support per RFC 4385 and RFC 5586.

Link Fault Management testing with 802.3ah OAM, capabilities include:

- Discovery mechanism to verify capabilities and provisioning of link partner
- Remote Loopback command for link performance testing
- Critical Link Event Notification

Connectivity Fault Management testing with 802.1ag and Y.1731, capabilities include:

- Linktrace message to perform path discovery
- Loopback message to test connectivity and isolate faults
- Continuity check messages to detect connectivity issues

Performance Management testing

with Y.1731, capabilities include:

- Frame Loss Measurement (ETH-LM) function for service frame loss ratio measurement
- Delay Measurement (ETH-DM) function for frame delay and frame delay variation measurement

Intelligent Network/Device Discovery

Easily discover and select another VeEX Ethernet tester or loopback device on the network under test. The local device will control the operation of the far end device, in either loopback or peer-to-peer mode (symmetrical or asymmetrical traffic generation mode). This feature greatly simplifies field testing since there is no need for a second technician to be at the far end configuring the test partner device.

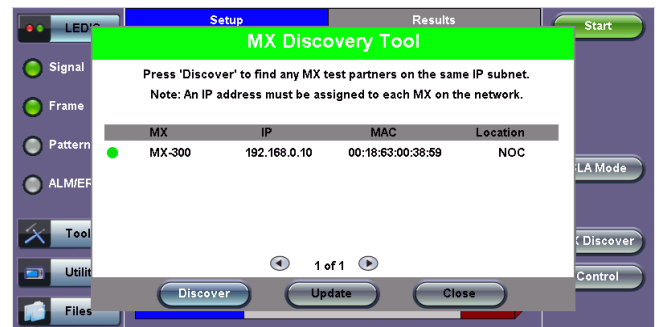

Smart Loopbacks

Four modes are available for looping back test traffic. At Layer 1, all incoming traffic is looped back unaltered. At Layer 2, all incoming unicast traffic is looped back with the MAC source and destination addresses swapped. At Layer 3, all incoming unicast traffic is looped back with the MAC and IP source and destination addresses swapped, and at Layer 4, all incoming unicast traffic is looped back with the MAC, IP, and UDP/TCP ports swapped.

Configurable traffic filters are supported on all MAC, IP, and VLAN fields to allow full control over looped traffic. Traffic is monitored while being looped and key traffic metrics such as frame type, rate, and error/alarms are displayed on screen. These can be compared to results at the far end to pinpoint issues more easily.

RFC6349 V-PERF TCP/UDP Test

A common source of customer complaints come from file transfer speeds not matching the throughput rates guaranteed in the SLA. While many factors affect TCP applications performance, including customer’s operating system hardware performance and settings (TCP window size), carriers need to prove SLA with a test tool that can show TCP performance independent of Operating System or Server limitations and present repeatable reliable results.

The test set V-PERF feature uses RFC6349 test methodology and metrics for qualifying network TCP/UDP performance. It offers a full line rate stateful TCP test with configurable window sizes, client and server modes as well as compatibility with iPerf servers.

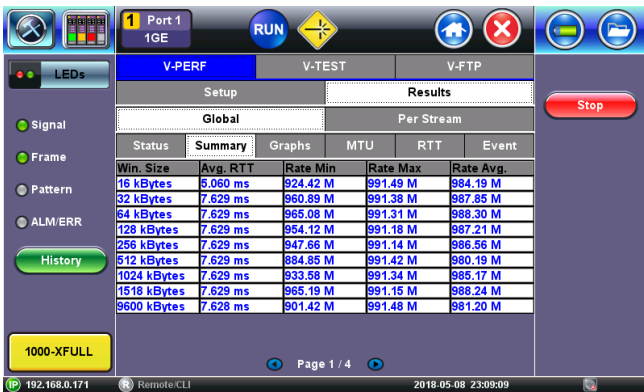

FTP Throughput and V-Test HTTP Throughput Test

FTP Throughput and V-Test features provide additional Layer 4-7 testing. The FTP Throughput feature allows the user to test up to full line rate FTP protocol performance to any FTP Server by uploading and downloading files. The V-Test feature qualifies network HTTP protocol performance by downloading and uploading files to a V-Test HTTP server. Both features can test up to the full line depending on the server specifications and limitations. Connection time to the server, data transfer time, line rate throughput rates, and protocol (FTP and HTTP) throughput rates key metrics are reported during the tests.

VLAN Scan and Traffic Monitor

VLAN Scan allows scanning up to 4096 VLAN IDs for switch configuration verification. Verify which VLAN IDs are the top bandwidth users and monitor up to eight live traffic streams (in terminate mode).

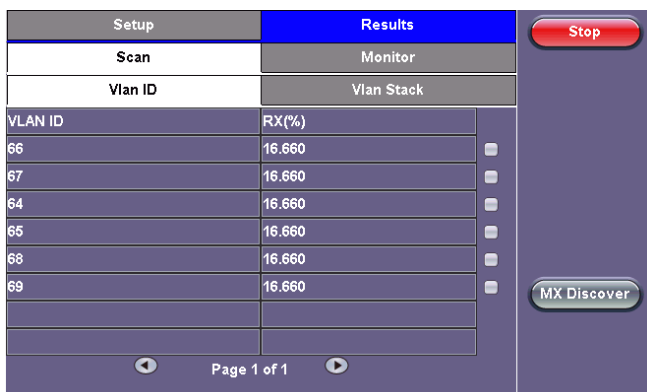

Delay Measurements

In addition to round trip delay measurements, the test set provides advanced one-way delay measurement capabilities. With GNSS option, one-way delay can be measured between remote test sets. The delay measurements are provided for each independent traffic stream.

Layer 2 Control Protocol Transparency Test

To verify handling of Layer 2 Control Protocol (L2CP) frames across Carrier Ethernet networks, the Layer 2 Control Protocol Transparency Test feature transmits a set of L2CP frames and verifies that they are forwarded through the network. This feature supports common L2CP frame types (as per MEF 45 standard) as well as Cisco L2CP frame formats.

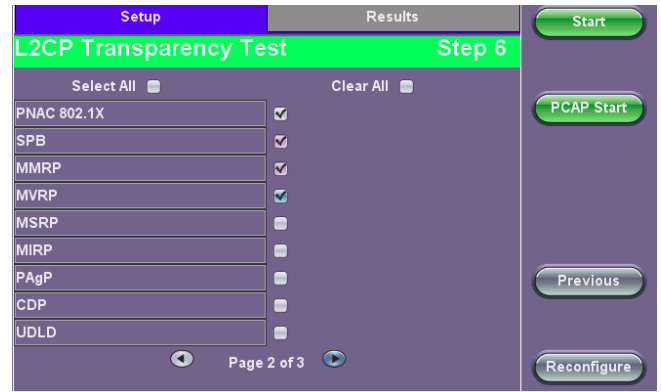

Auto Scripting

The Auto Scripting feature is the perfect tool for the lab environment where multiple short-term or long-term test configurations are required to stress the network equipment and/or network under test, in order to measure and qualify the performance capabilities. The feature is also important in field operations, not only to speed-up service turn-up times, but also to facilitate the entire workforce the same test profiles and test procedures for day-to-day operations.

The Auto Scripting application is an automated sequence of tests that can be carried out by selecting previously configured Throughput or BERT profiles. The profiles can be created with ReVeal and then loaded to the unit or created directly on the unit in the Throughput and BERT applications. Users can select up to ten profiles, each profile configured with its own duration. The duration can be in seconds, minutes, hours, or days. The test sequence will begin with the first profile configured with its corresponding duration, followed by each profile after that. At the end of each profile tested a results file will be stored automatically before the test sequence continues to the next profile. Users have the option to continue or stop the auto scripting test if errors or alarms are detected.

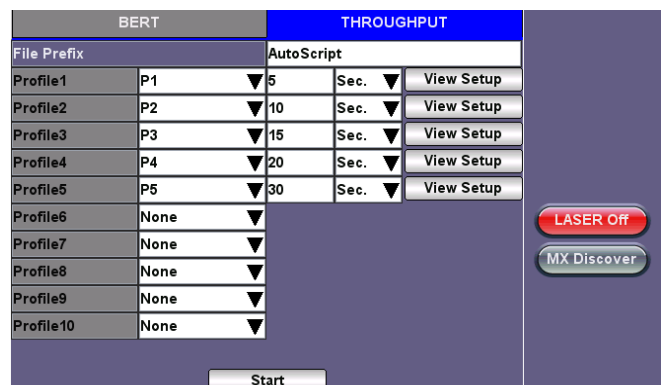

Network Troubleshooting Tools

Complementary to the transport layer tests provided with the RFC2544 and V-SAM Y.1564 test suites, the tester provides advanced application layer test capabilities with the following functions: Ping test, Trace route, and network discovery.

Packet Capture and Decode

Live packet capture with protocol decode. This function captures packets from the Ethernet test ports and provides packet, protocol summaries and Hexadecimal displays compatible with Wireshark. The captures can be saved in standard PCAP format and exported for analysis.

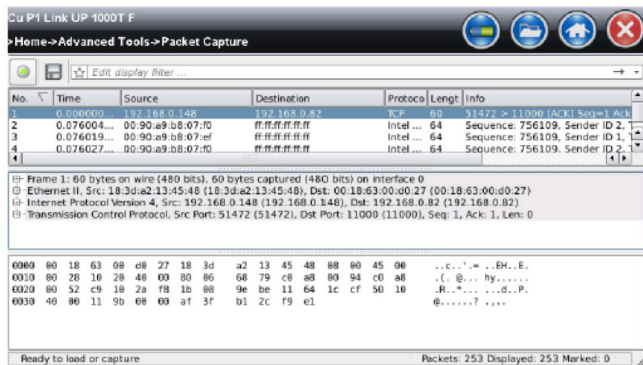

Ethernet Specifications

Electrical Interfaces

10/100/1000Base-T Ports: RJ45 connector

Ethernet Classification: Per IEEE 802.3

Optical Interfaces

1GE and 10GE LAN/WAN SFP/SFP+ optical Ports: LC connectors

**Ethernet and Fibre Channel share SFP or SFP+ ports*

***Data rates, performance, and supported transmission protocols are only guaranteed for SFP or SFP+ supplied by VeEX Inc. If selecting or using other vendors, users should exercise caution*

Modes of Operation

Terminate

Loopback

Pass Through Monitor

Traffic Generation

Layer 1 Unframed and Framed, Layer 2, Layer 3, Layer 4

Test Frame Header

- IEEE 802.3 and Ethernet II (DIX) frames
- Configurable Source and Destination MAC and Ethernet Type
- VLAN stacking up to 3 Q-in-Q tags w/configurable priority & type
- Fully configurable IPv4 or IPv6 header
- MPLS up to 3 labels with configurable Label/S/CoS and TTL fields
- MPLS-TP label with configurable LSP, PW and CW fields
- UDP/TCP header with configurable Source & Destination ports
- Provider Backbone Bridge (PBB) support with configurable Backbone MAC Source and Destination, I-SID, PBB-VLAN ID and priority

1GE Fixed or Uniform distribution frame size from 64 to 10000 bytes (Layer 4 tests Fixed frame size up to 1518 only,

10GE Fixed, Random and Increment/Decrement frame size distribution from 64 to 10000 bytes)

Traffic Pattern: Constant, Ramp, Multi Bursts, Single Burst

1GE Error Injection: Single and Count; Bit, CRC, Pause, IP Checksum, TCP/UDP Checksum

10GE Error Injection: Single, Count and Rate; Bit, CRC, Sync Header Error, Block Type Error, Pause, IP Checksum, TCP/UDP Checksum

Alarm Injection: Count (duration) or Continuous

- 10GE LAN: Local Fault, Remote Fault
- 10GE WAN SONET: Local Fault, Remote Fault, LOF, AIS-L, RDI-L
- 10GE WAN SDH: Local Fault, Remote Fault, LOF, MS-AIS, MS-RDI

Bit Error Rate Test

Test Patterns

- 1GE and 10 GE PRBS: $2^{31}-1$, $2^{23}-1$, $2^{15}-1$, $2^{11}-1$, normal and inverted patterns, All 0s, All 1s and User Defined (Layer 2,3,4)
- 1GE: HFPAT, LFPAT, MFPAT CRPAT, RDPAT, JTPAT, SNPAT (Layer 1 Unframed) CRPAT, CJPAT, CSPAT (Layer 1 Framed)
- 10GE: PRBS, LAN Seed A and B (Layer 1 Unframed), CRPAT and CJPAT (Layer 1 Framed)

Error Measurements: Bit/BER, FCS/CRC, Jabber/Runt frames, IP Checksum, TCP/UDP Checksum

Alarm Detection

- 10GE: LOS, LOSync, PAT Loss, Service disruption (current, total, last, min/max, # of occurrences), Local Fault, Remote Fault, PCS-HI-BER, PCS-LOBL, WAN SONET Alarms: LOF, AIS-L and RDI-L WAN SDH Alarms: LOF, MS-AIS, MS-RDI
- 1GE: LOS, LOSync, PAT Loss, Service disruption (current, total, last, min/max, # of occurrences)

Frame/Packet Statistics

- Multicast, broadcast, unicast, pause frames, frame size distribution
- Rates (min, max, average and current): frame rate, bandwidth utilization, frame rate, line rate, data rate
- Frame arrival time (min, max, average and current), Frame Delay Variation

Multiple Streams Throughput Testing

Up to 8 independent traffic streams generation and analysis, with configurable filters on 1GE interface

Up to 10 independent traffic streams generation and analysis, with configurable filters on 10GE interface

Each stream can be set with independent frame size, bandwidth, traffic profile, and QoS levels

MAC flooding feature: generates test frames with up to 4096 incrementing Source and/or Destination MAC addresses

VLAN flooding feature: generates test frames with up to 4096 incrementing VLAN IDs

Test Patterns: PRBS: $2^{31}-1$, $2^{23}-1$, $2^{15}-1$, $2^{11}-1$, normal and inverted patterns, All 0s, All 1s and User Defined

Error Measurements: Bit/BER (Single Stream only), FCS/CRC, Jabber/Runt frames, IP Checksum, TCP/UDP Checksum, Frame Loss (count and %), Out of Sequence

Alarm Detection

- 10GE: LOS, LOSync, Service disruption (current, total, last, min/max, # of occurrences), Local Fault, Remote Fault, PCS-HI-BER, PCS-LOBL, WAN SONET Alarms: LOF, AIS-L and RDI-L WAN SDH Alarms: LOF, MS-AIS, MS-RDI
- 1GE: LOS, LOSync, Service disruption (current, total, last, min/max, # of occurrences)

Frame/Packet Statistics

- Multicast, broadcast, unicast, pause frames, frame size distribution
- Rates (min, max, average and current): frame rate, bandwidth utilization, frame rate, line rate, data rate
- Frame arrival time (min, max, average and current), Frame Delay Variation

Round Trip Delay (RTD) and One Way Delay (OWD)

- Latency and asymmetry measurements
- Current, Min, Max and Average latency measurements
- Histogram tracking with configurable sampling period and long-term OWD recording to USB
- Configurable latency threshold and alarm
- RTD measurement (to a remote loopback)
- RTD resolution: 20 ns
- Local OWD measurement (between two ports)
- OWD resolution: 20 ns
- GNSS-assisted OWD measurements between different locations (P-to-P)*

Service Disruption (SDT)

- Per-stream inter-packet gap based measurement
- Total, Last, Min and Max SDT measurements with number of occurrences and violations
- SDT accuracy: 1 μ s
- Configurable Trigger (1 μ s to 3s) and Violation threshold (1 μ s to 3s)

Traffic Loss

- Per-stream traffic loss time count
- Current time, total time and number of occurrences
- Traffic Loss Trigger (100 ms to 10s)

* Requires GNSS Receiver option (Atomic Clock option recommended). Accuracy depends on GPS 1PPS.

RFC2544 Compliance Testing

Automated tests compliant with RFC2544 with configurable threshold values and maximum transmit bandwidth settings
Throughput, Latency, Frame Loss, and Back-to-Back (burst) tests
Frame sizes: 64, 128, 256, 512, 1024, 1280, 1518 bytes and 2 user configurable frames

Tests can be done to a remote loopback or in Peer to Peer mode to a remote test set configured as a responder

Peer to peer mode allows asymmetric bandwidth RFC2544 test

RFC2544 Advanced SLA Mode

RFC2544 compliant test on primary test stream with up to 7 independent background traffic streams

Each background stream can be set with independent frame size, bandwidth, traffic profile, and QoS levels

ITU-T Y.1564 V-SAM Test

V-SAM test suite compliant with ITU-T Y.1564 standard

Support for Multi-stream traffic generation, Service Configuration and Service Performance tests

Independently configurable for each stream

- Frame size: Fixed or EMIX pattern (1GE only)
- Bandwidth profile parameters: CIR, EIR, CBS (1GE only), EBS (1GE only) Traffic Policing
- Service acceptance criteria: FLR, FTD, IFDV, AVAIL

Simple summary Pass/Fail results tables and drill down capability with detailed measurements (Frame Loss, Frame Transfer Delay, Frame Delay Variation, Availability) for each service

Link Level OAM - IEEE 802.3ah

Modes: Active and Passive, with configurable Vendor OUI, Vendor SPI, MAX PDU length, and PDU rate

Discovery capabilities: remote loopback, link events, MIB retrieval

Link Events Notifications: Link Fault, Critical Event, Dying Gasp

Remote Loopback control

Service Level OAM-IEEE 802.1ag, ITU-T Y.1731 and MPLS-TP OAM ITU-T G.8113.1

MEP emulation with configurable MD name, MA name, local MEP ID, MD level, VLAN ID

ITU-T G.8113.1 configurable LSP and PW label, CoS, TTL, GAL Label 13 or 14, CoS, TTL, ACH Channel Type

Continuity Check Message (CCM): with priority level & interval selection

Loopback Messages (LBM/LBR): loopback message generation and response to destination MEP or MAC address

Link Trace Messages (LTM/LTR): link trace message generation and response to destination MEP or MA address with configurable TTL

Loss Measurement Messages (LMM/LMR): loss measurement message generation and response to destination MEP or MAC with configurable rate and number of messages

Delay Measurement Messages (DMM/DMR): delay measurement message generation and response to destination MEP or MAC with configurable rate and number of messages

Smart Loopback Mode

Layer 1: incoming traffic looped back unchanged

Layer 2: incoming traffic looped back with MAC source and destination addresses swapped

Layer 3: incoming traffic looped back with MAC and IP source and destination addresses swapped

Layer 4: incoming traffic looped with MAC, IP, and UDP/TCP ports swapped

Configurable traffic filters on MAC and IP source and destination addresses, VLAN ID and Priority, IP Precedence and TOS, UDP source and destination ports

All key measurements on received traffic provided on loopback unit

VePAL Discovery Function and Remote Control

Discovery function to all VeEX VePAL devices within subnet or manual control of VeEX VePAL devices in routed network

Remote Control of Loopback capability

Peer to Peer Controller/Responder configuration for RFC2544 test with asymmetric bandwidth test capability for end-to-end RFC2544 test

VLAN Scan and Monitor

Scans incoming traffic and discovers all VLAN flows including Q-in-Q tagging

Key statistics on traffic rates, alarms and errors are reported for monitored streams (up to 8)

Pass Through Monitor Mode

Pass through monitoring function between 2x 1GE or 2x 10GE fiber ports,, or 2x 1GE copper ports

Key statistics on traffic rates, alarms and errors are reported, as well as configurable performance thresholds

Layer 2 Control Protocol Transparency Test

- Selectable Layer 2 Control protocol frames and configurable frames
- Supported L2CP frame types per MEF 45 standard
- Cisco L2CP frame formats
- Selectable frame rate and count
- TX and RX frames statistics

IPv6

IPv6 compliant test traffic generation and analysis for all test applications (Y.1564 V-SAM, RFC2544, BERT and Multi-stream Throughput)

IPv6 Loopback capability

IPv6 Static or Stateless Auto Configuration, Ping and Trace Route functions

Layer 4-7 Features

V-Perf Test

TCP/UDP Throughput Compliant with RFC6349

Stateful TCP/UDP Test at line rate

TCP/UDP Client and Server modes

Compatible with iPerf Client/Server

MTU search per RFC4821

Round Trip Time Measurement

Configurable TCP Window sizes

Multi-Window size tests

Measurements: TCP/UDP Throughput rate (min, max, average), Transfer file size and duration, Transfer time ratio, Efficiency %, Buffer Delay %

V-Test

HTTP Throughput

Full line rate

HTTP client mode

Connection time to server

Total Data Transfer time

HTTP Throughput rates

Requires V-Test Server

Speedtest[®] powered node compatible with Ookla Speedtest Server Network

FTP Throughput Test

FTP Throughput

Full line rate

FTP client mode

Connection time to server

Total Data Transfer time

FTP Throughput rates

Compatible with Linux and Windows FTP servers

Network Troubleshooting Tools

IP Tools

Provides basic Ethernet and Internet connectivity to the test set as well as connectivity troubleshooting tools to Ethernet test ports (10/100/1000BaseT, 100FX/1000BaseX, 10GE) and Management port (10/100BaseT)

IP: IPv4 (Static, DHCP) and IPv6 (Static, Auto) and PPPoE

VLAN support

Ping, Trace Route check

HTTP Web browsing internet connectivity check

Traffic Shaping: constant, ramp, burst

Frame Length Configuration: 2148 bytes maximum

Packet Capture and Decode

Line rate Packet capture from test interfaces

- 10/100/1000BaseT
- 100FX/1000BaseX
- 10GE

Configurable capture filters

- MAC and IP
- UDP and/or TCP
- Multicast, Broadcast, IP Checksum error, UDP/TCP Checksum Error events

Integrated packet decode compatible with Wireshark

Packet captures can be saved and exported PCAP capture format, compatible with Wireshark

Net Wiz

Network Discovery Tool

- Discovery: TX Frames, RX Frames, RX Errors, Advertised Speed, Advertised Duplex, Devices found, Networks found
- Devices: Total number, Routers, Servers, Hosts
- Device Details: Attribute, IP address, MAC address, Group Name, Machine Name, Ping OK
- Networks: IP Subnets, Hosts, Domains, Hosts Names

VoIP Testing

Take advantage of software options offering different test methods to verify and provision your VoIP network.

VoIP Check

Simulates a VoIP call to the nearest router and measures the round trip MOS score and related VoIP parameters.

The VoIP check mode tests the network readiness for VoIP without placing an active VoIP call. This mode allows for service verification before SIP/H.323 infrastructure is in place or if credentials are not known. This test focuses on packet transmission quality and metrics by sending traffic (ICMP Ping) matching VoIP call traffic properties.

VoIP Expert

VoIP Expert is a simple and effective tool for pre-qualifying VoIP service and verifying triple play implementations.

The VoIP Expert Client/Server mode allows a test set connected to a VX1000 server to exchange upstream and downstream files to exercise the connection under VoIP calls conditions.

Bi-directional Mean-Opinion-Score (MOS), Transmission-Rating-Factor (R-factor) and other critical network related parameters are measured and test results are displayed on both field test units and the VX1000 software. The VX1000 software can be installed on any server and accepts up to 16 simultaneous VoIP test calls from compatible VePAL100+/300 series products.

Setup		Status		Ping	
Trace Route	Web/FTP	ARPWiz	VoIP		
Setup	Status	Trace	DTMF		
Status	MOS/R	Packets	Events		
		UP	DN		
MOS-LQ		4.20	4.20		
MOS-CQ		4.16	4.16		
R-LQ		93	93		
R-CQ		91	91		
Gap R		91	91		

VoIP Call Expert – Emulates an IP phone to place and receive calls using SIP or H.323 protocols. Real-time evaluation of voice quality with a complete set of measurements is available at the end of the call, including packet statistics, jitter statistics, and MOS and R-factor call quality scores. Support VoIP trunk test with bulk call generation of up to 24 simultaneous calls.

Setup		Status		Ping	
Trace Route	ARPWiz	VoIP			
Setup	Status	Trace	DTMF		
Status	MOS/R	Packets			
Peer URL	1082@192.168.0.176				
Registration Online	Status :Call connected NO.24(200 OK)				
Listening	Connecting	Connecting	Connecting	Connecting	Connecting
Connecting	Connecting	Connecting	Connecting	Connecting	Connecting
Connecting	Connecting	Connecting	Connecting	Connecting	Connecting
Connecting	Connecting	Connecting	Connecting	Connecting	Connecting

VoIP Testing Specifications

Codecs: G.711 μ -law, G.711 A-law

Measurements: MOS (CQ and LQ) and ITU-T G.107 R-factor (CQ and LQ)

Packet Statistics: Data throughput rate, packet loss, packet discard, OOS, duplicate, jitter

VoIP Check

- Simulates VoIP call to the nearest router by sending ICMP traffic with payload/rate matching VoIP traffic properties

VoIP Expert

- Client/Server mode provides bi-directional measurements
- Compatible with any VeEX field tester or centralized VeEX VX1000 Server software

VoIP Call Expert

- VoIP call setup: supports SIP and H.323 protocols
- Multi-call support: Up to 24 concurrent calls
- Configurable jitter buffer (fixed or dynamic)
- Incoming call Auto Answer
- STUN support
- Talk/Listen with built in microphone and speaker
- DTMF test (RFC4733)
- Signaling trace with protocol decode

IPTV Explorer

IPTV Service Providers nowadays have to ensure the transport layer and MPEG payload are both within defined limits, because simply checking packet loss, jitter and related impairments of the Ethernet distribution network is not enough to evaluate the quality of the IPTV content carried in the upper protocol layers. The IPTV Explorer option extracts the MPEG payloads from the Ethernet streams, decodes and displays them to check transport and programming content so that QoS and QoE can all be assessed.

Media-Stream-Based Algorithm

A proprietary and sophisticated algorithm analyzes the IP stream to assess and derive video quality and improve accuracy of quality scores.

- **Frame structure/GoP detection** – Identifies I, B, and P frames in both unscrambled and encrypted video streams, to determine GoP length and the rate and distribution of packet loss in each frame
- **Per-frame quality computation** – Quality in each frame using the frame type, frame size, codec type, bandwidth, and packet loss data. For P and B frames, tester models the loss propagated from earlier reference (I or P) frames
- **Bandwidth estimation** – the bandwidth used by certain types of video frames is analyzed to estimate the quantization level applied by the video encoder

Program Identifier (PID) Statistics

PID statistics provide critical information about the MPEG transport stream. The bandwidth and packets associated with each individual stream are listed allowing the technician to check the video, audio and data content and to check for any “illegal” PIDs.

Transmission Quality Score

QoS parameters are evaluated and presented in an intuitive manner so that technicians unfamiliar with MPEG signals are able to make accurate decisions to ensure maximum service availability.

- Audio and Video MOS scores associated with the particular video/audio codec used and transmission quality are reported
- VSTQ (Video Service Transmission Quality), is a codec-independent scoring that rates the ability of the network to reliably transport video
- ETSI TR 101 290 metrics are good indicator of transport associated errors

Setup	Analysis			Viewer
IPTV-TS Summary		Streams Summary		Details
PID Map	Video		Audio	ETR 290
	Min	Max	Avg	Below Threshold(%)
Absolute MOS_V	1.00	2.67		0.000
Relative MOS_V	1.09	3.20		0.000
MOS_AV	1.52	2.55	1.81	0.000
VSTQ	50.00			
EPSNR				
EPSNR ATIS	42.58dB			

Page 1 of 4

IPTV Image Viewer

The IPTV viewer decodes un-encrypted streams and can be used as a quick channel identifier to verify PID assignment.

IPTV Testing Specifications

Mode: Monitor, STB emulation

Stream configuration: Unicast, multicast, IP address, Port number

- Analyze up to 8 streams simultaneously
- IGMP and RTSP signaling support

Codecs: MPEG2, MPEG4 (Part2) and MPEG4 Part10 (H.264)

Probe function with streams auto-detection

IPTV image viewer for channel identification (does not decode encrypted streams)

Stream Analysis

- PIDs count
- PID MAP
- Transport Error count
- Data rates: Video, Audio, Data (Bandwidth and Packet Counts)

Video Analysis

- MOS_Video, Video Service Transmission Quality (VSTQ), Estimated Peak Signal to Noise Ratio (EPSNR ATIS)
- I/B/P Frame statistics (Bandwidth, # Frames Received, Lost, Impaired)

Audio Analysis

- MOS_Audio

TR 101 290 Metrics

- Sync loss, sync byte error, PAT/PAT2 error, Continuity error, PMT/PMT2 error, PID error, transport error, CRC error, PCR discontinuity, PCR accuracy error

Synchronous Network Features

Many services and underlying functions running on modern digital communications networks depend on accurate frequency and/or phase synchronization for correct operation. SDH/SONET, PDH/DSn, SyncE, 1588v2 PTP and GNSS-disciplined clocks are some of the technologies being used to deliver synchronization to the edge of the network. Their recovered clocks must be verified in the field, often in places where no traceable or reliable references are available.

The advent of carrier Ethernet as the transport technology of choice for metro networks and next generation high-speed cellular networks, have made SyncE and PTP very popular solutions for bridging the frequency, phase and time synchronization gap created by those otherwise asynchronous links. Pushing synchronization testing farther away from the core, to the very edge of the network footprint, making portable and self-contained test sets a strong requirement.

IEEE 1588v2/PTP Master Clock Emulation Mode

Master Clock emulation allows network synchronization properties to be verified prior to service delivery or during routine maintenance tasks. Using the internal precision clock or an external 1.544 Mbps, 2.048 Mbps, 1.544 MHz, 2.048 MHz, 10 MHz, 25 MHz, 125 MHz, or 1 PPS signal as the reference clock, the unit generates the PTP messages needed by a Slave device to synchronize.

The reference clock can further be applied to an outgoing 1.544 Mbps or 2.048 Mbps signal via balanced RJ45 or bantam interfaces or alternatively a 1.544 Mbps, 2.048 Mbps, 10 MHz, 25 MHz, 125 MHz, or 1 PPS signal can be generated on the unbalanced BNC port for other synchronization requirements. In this mode, the unit can be programmed to generate PTP messages at different rates.

Master clock emulation

- Unicast and multicast master emulation
- Layer 2, IPv4 and IPv6 support
- 2-step clock
- Configurable announce, Sync and Delay_req rates and domain number, Clock class and Clock priority

IEEE 1588v2/PTP Slave Clock Emulation Mode

Emulates a Slave Clock device where synchronized clock is extracted using the PTP procedure. After an IP layer connection is achieved, clock identities are exchanged between the test unit and the far end Master clock device. The PTP messages can be monitored and decoded.

In the Summary tab, an overview of the Total, CRC, lost, error, out of order and duplicated messages are displayed. The Message tab provides a concise record of all PTP message related items, while the Results tab provides detailed statistics and values for Packet Delay Variation (PDV), Master to Slave (T1) and Slave to Master (T4) delay measurements and Inter-Packet Gap (IPG).

Slave clock emulation

- Unicast or multicast slave emulation
- Layer 2, IPv4 and IPv6 support
- 1-step or 2-step clock
- Configurable announce, Sync and Delay_req rates and domain number

PTP Measurements

- Message counters (Sync, Follow up, Delay Request/Response, Pdelay Request/Response, signaling, management) and statistics (Loss, CRC error, duplicate, out of order)
- PTP messages display and decode
- PTP messages capture in pcap format
- PDV measurements and graph display (Sync PDV, Delay_Req PDV)
- Master to Slave (T1) and Slave to Master (T4) delay measurement
- Boundary Clock TE measurement
- Master and Slave Clock Emulation with 2 ports (TX340sm)
- IPG measurements and graph display

PTP Through Mode and PDV analysis

- 2 Modes of operation: Port 1 to Port 2 Pass-through or transparent monitoring with optical splitter
- Bi-directional analysis of 1588 PTP traffic
- PTP Packet Statistics (received, lost, errors)
- Ethernet Statistics
- Bi-directional PTP traffic capture (pcap file)
- PDV graphs
- Master to Slave (Forward delay) and Slave to Master (Reverse delay) measurement
- PDV Measurements and export via USB (with accurate timestamp)
- Slave wander analysis
- Packet MTIE and TDEV Analysis
- PDV FPP, FPC and FPR metrics per ITU-T G.8261.1 standard

ITU-T G.8261 SyncE Master Clock Emulation Mode

The reference clock can be based on the internal precision clock or from an external clock source at 1.544 Mbps, 2.048 Mbps, 1.544 MHz, 2.048 MHz, 10 MHz, 25 MHz, 125 MHz, or 1 PPS rate. The output reference clock can be synchronized to 1.544 Mbps or 2.048 Mbps and provided at the DS1/E1 port or a 1.544 MHz, 2.048 MHz, 10 MHz, and 1 PPS clock signal can be made available on the unbalanced BNC port.

ITU-T G.8261 SyncE Slave Clock Emulation Mode

Extracts clock information from the incoming Ethernet signal at the 10/100/1000Base-T, 100Base-FX, 1000Base-X, and 10GBase-X interface. The recovered reference clock can be applied to a 1.544 Mbps or 2.048 Mbps signal at the DS1/E1 port or a 1.544 MHz, 2.048 MHz, 10 MHz, 25 MHz, 125 MHz, or 1 PPS clock signal can be made available on the unbalanced BNC port. Clock and Wander are measured against the reference clock.

ESMC SSM Clock Quality Messages

SDH/SONET (S1) and E1 (Sa) SSM QL message encoding and decoding SyncE ESMC/SSM messages generation with configurable type and rate. Includes ESMC SSM messages TX/RX display, decode, counters and capture

IEEE 1588v2 clock class generation, decoding and message capture Master/Slave clock emulation

- ESMC SSM generation: configurable message type and rate
- #### Measurements
- ESMC SSM messages counters
 - ESMC SSM messages display and decode
 - ESMC SSM messages capture in pcap format

Synchronization Messages Capture

Message capture and decode for SyncE ESMC/SSM and IEEE 1588v2 messages. Captures in pcap format for further analysis using built-in or external protocol analyzers.

Recovered Clocks

Master clock emulation: Offers recovered clock output (clock translation) for external analysis or to provide timing to other devices

Slave clock emulation: Offers recovered clock output (clock translation) for external analysis or to provide timing to other devices

Recovered Clock Output (Clock Translation)

- 1PPS, 2.048 Mbps, 2.048 MHz, 10 MHz, 25 MHz, 125 MHz

Reference Clock

Reference Clock (Master Emulation and Wander/Phase Measurements)

- Internal, GNSS 1PPS (Raw), Atomic 1PPS, Atomic 10 MHz
- External: 1PPS, 1.544 Mbps, 1.544 MHz, 2.048 Mbps, 2.048 MHz, 10 MHz, 25 MHz, 125 MHz

Clock Wander & Phase Measurements

This option compares two physical clock sources and measures TIE (wander) or Timing Error (absolute phase error) differences between the signal present at the RX1 (BNC) test port and the external reference connected to the CLK (SMA) port or the optional internal free-running or GNSS-disciplined Atomic clock. Reports current, minimum, maximum and average phase differences

- Phase Error vs. Time on-screen graph (monitor the last 600s)
- Wander Resolution: 0.2 ns
- Phase Error Resolution: 1 ns
- Phase Accuracy: ± 3.2 ns

Signals Under Test

- Frequency: 1.544, 2.048 and 10 MHz (sine or square)
- Data: 1544 and 2.048 Mbit/s
- Phase/Timing: 1PPS

Clock References

- Frequency: 1.544, 2.048, 10 MHz, internal Atomic 10 MHz
- Data: 1.544 and 2.048 Mbit/s
- Phase: External 1PPS, internal Atomic 1PPS and GNSS 1PPS

Recovered Clock Wander Measurements

These options measure the wander characteristics of the data clock recovered by the test set slave emulation, against an external reference connected to the CLK (SMA) port or the optional internal free-running or GNSS-disciplined Atomic clock.

Signals Under Test (recovered clock)

- T1, T3, E1, E3, STM-10, OC-3
- SyncE Slave
- 1588 V2/PTP slave (raw clock)

Clock References

- Frequency: 1.544, 2.048, 10 MHz, internal Atomic 10 MHz
- Data: 1.544 and 2.048 Mbit/s
- Wander Resolution: 0.2 ns

Real-time Wander & Phase Data Logging

This option exports real-time TIE or Phase measurements to a USB memory for further post-processing using the built-in or PC-based MTIE & TDEV Wander Analysis applications.

Modes: E1, E3, DS1, DS3, STM-10, OC-3, SyncE, IEEE 1588v2, external clock signals

Sampling rates: 1/s, 5/s, 10/s, and 30/s

Recording Time: Limited only by the size of the USB memory

File formats

- VeEX's native TIE and Phase (TE)
- Open CSV TIE and Phase (TE)

Built-in MTIE/TDEV Wander Analysis

This option enables the test set to analyze up to three days' worth of wander measurement data and compare it against standard masks for a PASS/FAIL assessment, without the need for a PC. The analysis can be performed while the test is still running for run-time verification.

- Provides further post-processing of clock stability data, such as MTIE and TDEV
- Real-time or post analysis modes
- Frequency offset calculation and removal for relative TIE analysis
- Standard MTIE and TDEV masks
- MTIE and TDEV results and mask export to CSV
- Direct PDF report generation to USB



VeEX MTIE/TDEV Wander Analysis PC software

- Provides further post-processing of clock stability data, such as MTIE and TDEV for long-term tests
- Frequency offset calculation and removal for relative TIE analysis
- Partial offset calculation based on display range
- Standard and user-programmable masks
- PDF report generation
- Fully resizable window, to accommodate any screen size and provide detailed zoom levels
- Compact stand-alone Windows® software. It can be carried in the same USB memory as the TIE data. No installation is necessary
- Compatible with VeEX native and CSV formats

Precision Timing References

The test platform offers two internal, accurate and stable clock reference options:

- GNSS receiver
- Chip-scale Atomic Clock

They provide precise timing to test applications. These physical clocks can be used as a reference for frequency, phase and wander measurements, or other time sensitive tests like one-way-delay (symmetry) measurements.

Disciplining and holdover: Combining the long-term accuracy of the GNSS option, the stability of the Atomic clock option and its battery operation, this test platform can offer precision clock references even in places where satellite signals are not available or can't be trusted (e.g. in-building or urban canyon applications).

Jitter Measurement Options

Complete SDH/SONET and PDH/DSn Jitter Test Suite

- Jitter Measurements
- Jitter Generation
- Maximum Jitter Tolerance test
- Jitter Transfer Function test

Graphical and tabular results

Output jitter performance mandated by ITU-T 0.171/0.172 and Telcordia GR-499/253 standards is evaluated by measuring the recovered clock of the incoming signal (E1, E3, STM-1o and DS1, DS3, OC-3) traversing the network. In SDH/SONET networks there is a great potential for the accumulation of jitter to degrade network performance, thus it is imperative that components and the network as a whole be tested and screened regularly for jitter to ensure that optimum levels of quality can be maintained.

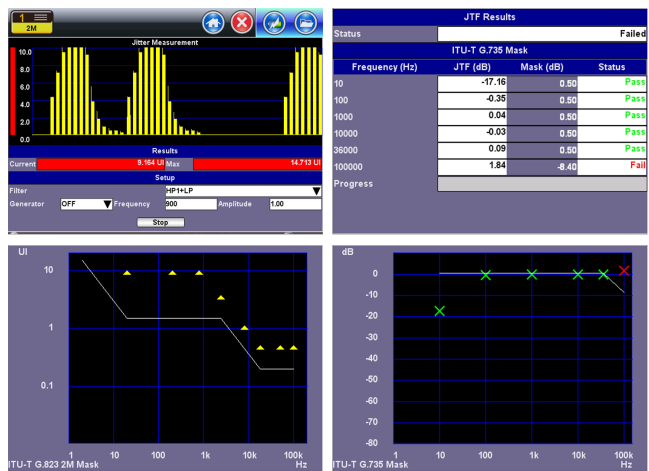

Jitter Measurements

HP1+LP (Wide-band Jitter) filter

- E1 (2M) 700 Hz to 100 kHz
- E1 (2M) 20 Hz to 100 kHz
- E3 (34M) 100 Hz to 800 kHz
- DS1 (1.5M) 10 Hz to 40 kHz
- DS3 (45M) 10 Hz to 400 kHz
- STM-1/OC-3 (155M Optical) 500 Hz to 1.3 MHz

HP2+LP (High-band Jitter) filter

- E1 (2M) 18 Hz to 100 kHz
- E3 (34M) 10 Hz to 800 kHz
- DS1 (1.5M) 18 Hz to 100 kHz
- DS3 (45M) 30 Hz to 400 kHz
- STM-1/OC-3 (155M Optical) 65 Hz to 1.3 MHz

Parameters: Current peak-peak, Maximum peak-peak

Color-coded Pass/Fail indication according to ITU-T limits

Standard Pass/Fail masks

Units: UI (Unit Interval)

Resolution: 0.01 UI

Accuracy: Per ITU-T 0.171 and 0.172

Graphical display of Jitter behavior over time

Test Duration: Continuous

Jitter Generation

Frequency: 10 Hz to 1.3 MHz (Wander: 1 Hz to 9 Hz)

Amplitude: 0.01 to 50 U_{lpp}

Resolution: 1 Hz, 0.01 UI

OTN, SDH, SONET, PDH, DSn

Key Features

- Flexible wavelength and bit rate options using industry standard pluggable optics
- OTN: OTU2, OTU1, OTU2e, OTU1e
- SDH: STM-64/16/4/1/0
- SONET: OC-192/48/12/3/1, STS-3/1
- PDH/DSn: DS1, DS3, E1, E2, E3, E4
- EoOTN Testing with OTU1e, OTU2e, ODU0 and ODUflex with bulk, and Ethernet payloads
- Coupled or independent Tx and Rx settings
- Tandem Connection Monitoring
- Service disruption testing (SDT) and APS
- Round trip delay on all interfaces and payload mappings
- Jitter/Wander Analysis (E1, E3, DS1, DS3 and STM-10, OC-3)

Quick and Intuitive Graphical Setup

The combination of OTN, SDH/SONET and PDH/DSn, common in today's transport network environments, can create complex test scenarios. Therefore technicians and field engineers need a tool that is quick and easy to configure. Intuitive graphics, drop down menus and touchscreen operation greatly simplify test interface, signal structure, payload mapping and test pattern setup.

Test configuration, menus, and results are presented in VeEX's intuitive hierarchical test signal builder GUI, requiring little or no training for new or existing VePAL™ users, maintaining a consistent user experience from the lab to the field.

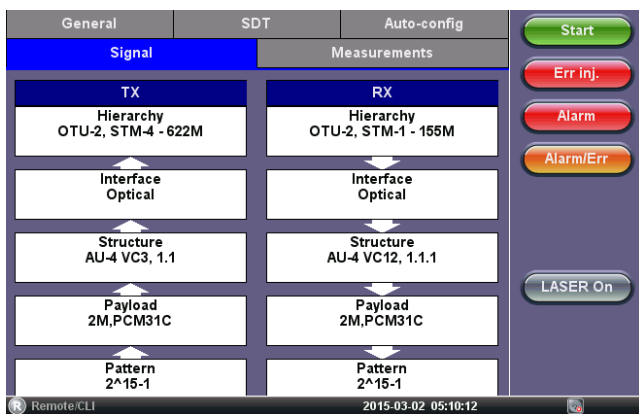

The transmitter and receiver can be set up independently, or coupled depending on the application. Framed signals can be equipped with unstructured or structured payloads with selected test pattern filling the entire test payload (Bulk) or a structured payload (SDH/SONET framed client signal) with or without PDH/DSn multiplexed clients. The test payload can be sent in one channel only or broadcasted to fill the entire link.

Layer-based graphical configuration interface allow users to build the test signal in a logical layer by layer sequence

- OTN/SDH/SONET/PDH/DSn interface selection
- Optical or Electrical signal settings
- Mapping and Multiplexing
- Payload (Bulk, multiplexed, or Ethernet)
- Test Pattern (CBR) or Traffic (Packets)
- Independent or Coupled TX and RX configurations

Physical Layer Testing

Verifying that signals are within prescribed specifications and limits is recommended prior to performing framing and payload analysis. High optical power levels can saturate receiver equipment, while low power levels are susceptible to noise which result in bit errors. Clock tolerances for each individual signal hierarchy is clearly defined by Telcordia and ITU-T recommendations and should be verified as part of any acceptance/conformance test.

Advanced Payload Mapping and Multiplexing

Test the operation of Add/Drop Multiplexers, Digital Cross Connects and other Network Elements (NE) by verifying the correct mapping and de-mapping of different tributaries and payloads into OTN, SDH and SONET containers, monitoring any anomalies and defects at every multiplex level, according to ITU-T and Telcordia recommendations.

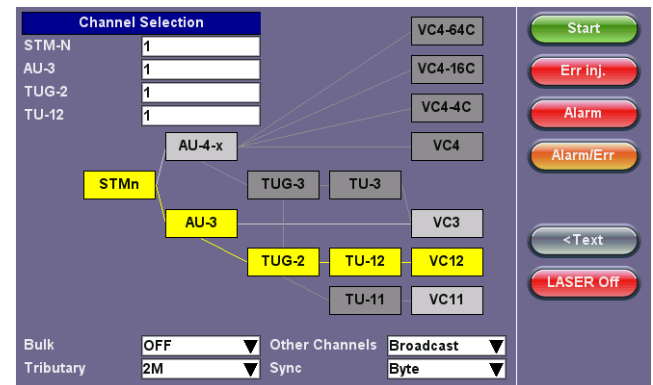

PDH/DSn client can be multiplexed and mapped into SDH/SONET, which in turn can be mapped and multiplexed into OTN using synchronous or asynchronous modes. In synchronous mode the Optical Payload Unit (OPU) clock is derived from the mapped client signal while in asynchronous the OPU clock is independent.

Complete Overhead Decoding and Generation

Binary, hexadecimal and detailed text decode of all applicable Section, Path overheads and Framing word bytes are performed through individual byte and bit selection or through dedicated test applications (e.g. TCMi, APS, Payload Labels, Pointer Tasks).

Analysis																	
FAS						MF	SM			GCC0			RES		RES	JC	
OA1	OA1	OA1	OA2	OA2	OA2	8E	TTI	BIP	BEI	TTI	BIP	BEI	TTI	BIP	BEI	00	00
F6	F6	F6	28	28	28		TI	2E	00	TI	24	00	TI	C7	00	00	00
RES			DM	TC	TCM6			TCM5			TCM4			FT	RES	JC	
						TTI	BIP	BEI	TTI	BIP	BEI	TTI	BIP	BEI	FT		
00	00	00				TI	24	00	TI	24	00	TI	C7	00		00	00
TCM3			TCM2			TCM1			PM			EXP			RES	JC	
TTI	BIP	BEI	TTI	BIP	BEI	TTI	BIP	BEI	TTI	BIP	BEI	RR	RR	RR			
TI	C7	00	TI	E4	00	TI	E4	00	TI	F3	01	00	00	00	00	00	00
GCC1			GCC2			APS/PCC			RES						PSI	NJO	
00	00	00	00	00	00	00	00	00	00	00	00	00	00	00	00	00	00
															FE	00	

Overhead byte control allows the manipulation and easy encoding of transmitted overhead bytes in both terminated and payload through modes to stress the network responses to various conditions.

Tandem Connection Monitoring (TCM)

TCM helps segment the end-to-end path to diagnose, isolate and troubleshoot individual sections and resolve finger-pointing in inter-carrier and multi-region scenarios.

Service Disruption Time and APS

SDT and Automatic Protection Switch timing measurements use trigger events to measure outages and link recovery times at different levels and evaluate them against Pass/Fail criteria. It also provides detailed events recording to understand what happened during the service outage.

Error Insertion and Alarm Generation

Alarms and Errors can be inserted into any of the mapping or multiplexing layers, from OTN signal to the test payload itself. A full range of OTN, SDH/SONET and PDH/DSn defects and anomalies are supported depending on the signal structure setup. Single errors, preset rates or user-defined error rates are supported.

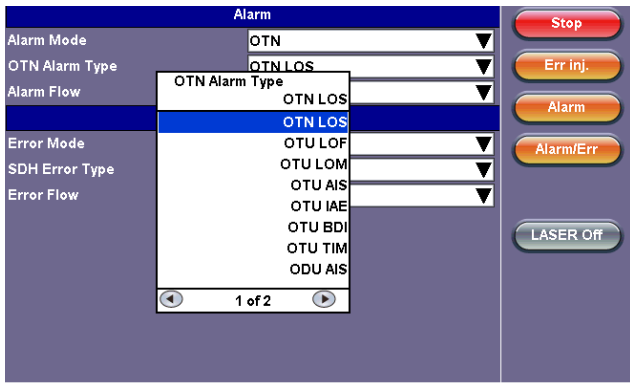

Intuitive Test Results

A summary screen quickly reports signal status and critical Error and Alarm parameters with easy-to-read Pass/Fail indicators. Additional screens accessed via a simple tab system display signal levels, anomalies and events.

Analysis	Histogram	Graph	Event Log
Summary	Errors/Alarms		Signal
ST:03/02 05:13:10 ET:00/00:02:14			
LOS Alarm			OK
OTN Alarms			OK
OTN Errors			OK
SDH Alarms			OK
SDH Errors			OK
PDH Alarms			OK
PDH Errors			OK
No errors - OK			

Alarms and Errors overview with history indicators provide direct (touch) access to counters and statistics and complement the soft LEDs with a layered representation of all defects and anomalies.

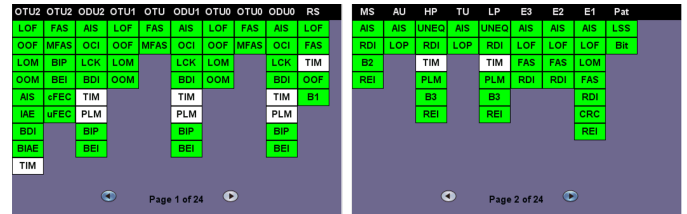

Powerful Measurement Histograms

Visual representation of individual or simultaneous measurement results over time, with 1-second resolution simplifies correlation of alarm and error occurrences.



Performance Analysis

Bringing-into-service (BIS), In-service and out-of-service (OOS) performance evaluations according to GR-253, G.821, G.826, G.828, G.829, G.8201, M.2100, M.2101. The test set analysis screens present Pass/Fail criteria for each performance parameter, based on Telcordia/ITU-T standards.

Line and Payload Frequency Measurements

Frequency and offset present in the Optical Transport Unit (OTU) line, Optical Payload Unit (OPU), SDH/SONET client and PDH/DSn multiplexed layers are measured to verify basic master-slave synchronization settings.

Analysis	Histogram	Graph	Event Log
Summary	Errors/Alarms		Signal
Frequency			
OTN current (bps)			10709225031
Offset (ppm):			0.0
Min (ppm):			0.0
Max (ppm):			0.0
SDH current (bps)			622079960
34M current (bps)			34367928
8M current (bps)			8447982
2M current (bps)			2047996

TX Clock Sources

- Internal: ± 2.5 ppm XO
- Recovered: from the incoming signal (Rx)
- External reference via CLK (SMA) connectors
 - 1.544 MHz, 2.048 MHz, 1.544 Mbps, 2.048 Mbps
- Precision Clock Sources
 - Built-in Atomic Clock option provides 10 MHz and 1PPS references and can be disciplined to the built-in GNSS receiver option (refer to TX300s platform for details)
- Tx Frequency Offset: Up to 150 ppm (25,000 ppm for E1) in steps of 0.1 ppm for both optical and electrical interfaces
- Clock recovery (pulling range) per ITU-T G.703

Measurement Clock References

Internal: ± 2.5 ppm XO

External Clock Input

- Unbalanced 75 Ω SMA
- 1.544 MHz, 2.048 MHz, 1.544 Mbps, 2.048 Mbps

Precision 1PPS and 10 MHz References

- Built-in GNSS Clock option (TX300s platform)
- Built-in Atomic Clock option (TX300s platform)

Optical Interfaces

SFP+ and SFP pluggable transceivers conforming to Multi Source Agreement (MSA) specifications

Compliant to ITU-T G.957/G.691 Optical interfaces and systems relating to SDH

Optical Power Measurement: ± 2 dB accuracy, 1 dB resolution

Safety: Class 1, per FDA/CDRH, EN (IEC) 60825 eye safety regulations

Operating temperature range: -10°C to 70°C

OTN Testing

The test set offers a full range of OTN testing capabilities, including service-activation (Bringing-into-Service), performance verification, maintenance, and troubleshooting. It offers Multi-Layer testing for Physical layer, OTU/ODUk, multiplexed or bulk payloads, and EoOTN with Ethernet traffic generation up to 100% rate.

Key Features

- OTU2 and OTU1
- OTU2e and OTU1e over-clocked bit rates
- EoOTN testing with internally generated Ethernet payload mapped into OTU1e, OTU2e, ODU0 or ODUflex
- Synchronous and asynchronous mapping of SONET/SDH signals, including multiplexed PDH/DSn payloads
- OTU, ODU, OPU overhead manipulation and monitoring
- OTU, ODU, OPU layer alarms/errors generation and analysis
- OTU, ODU, TCMi trace messages
- Forward error correction (FEC) testing
- Tandem Connection Monitoring
- Service Disruption Time measurement and Events tracking
- Frequency offset generation

OTN Interfaces

Standards: ITU-T G.709, ITU-T G.798, ITU-T G.872

- OTU2e 11.095 Gbps
- OTU1e 11.045 Gbps
- OTU2 10.709 Gbps
- OTU1 2.666 Gbps

Operating Modes

Normal (terminal)

- The instrument terminates the line, serving as source and sink for the generated traffic
- Offers full access to Overhead and Payload alarms and error generation and monitoring

OTN Mappings

- ODU2-Bulk (test pattern)
- ODU2-STM-64 or OC-192, synchronous and asynchronous, including all supported mappings and multiplexed tributaries, down to E1/DS1 (Nx64/Nx56k)
- ODU1-Bulk (test pattern)
- ODU1-STM-16 or OC-48, synchronous and asynchronous, including all supported mappings and multiplexed tributaries, down to E1/DS1 (Nx64/Nx56k)
- ODU2e-Bulk and 10GE payloads
- ODU1e-Bulk and 10GE payloads
- ODU0-Bulk and 1GE payloads
- ODUflex with Nx1.25G Ethernet payloads

Advanced sub-rate multiplexing and mappings of SDH/SONET payloads into OTN, including multiple ODUk levels, with ODTU2.1/ODTU12-ODTU01, AMP, BMP and GMP support. VC/STS/VT and PDH/DSn sub-multiplexing are also supported

- OTU1: ODU1-Bulk, ODU1-STM16, ODU1-ODU0-STM4/1
- OTU2: ODU2-Bulk, ODU2-STM64, ODU2-ODU1-STM16, ODU2-ODU0-STM4/1, ODU2-ODU1-ODU0-STM4/1

OTU Layer

Alarm and Error Monitoring

- Alarms: LOF, OOF, LOM, OOM, OTU-AIS, OTU-IAE, OTU-BDI, OTU-BIAE, OTU-TIM
- Errors: OTU-FAS, OTU-MFAS, OTU-BIP, OTU-BEI, Correctable FEC, Uncorrectable FEC

ODU Layer

Alarm and Error Monitoring

- Alarms: ODU-AIS, ODU-OCI, ODU-LCK, ODU-BDI, ODU-TIM
- Errors: ODU-BIP-8, ODU-BEI

OPU Layer

Payload Type (PT): Generates and displays received PT value

Expected Payload label setting

Enable/Disable PLM monitoring

Alarm and Error Monitoring

- Alarms: OPU-PLM

BER Test

Alarm and Error Monitoring

- Alarms: LSS (Loss Sequence Synchronization)
- Errors: Bit (Test Sequence Error)

Test Patterns

The following test sequences can be generated to fill the payload

- PRBS: $2^{31}-1$, $2^{23}-1$, $2^{20}-1$, $2^{15}-1$, $2^{11}-1$, 2^9-1 , 2^7-1 , QRSS
- Fixed: 0000, 1111, 1010, 1100, 1in8, 2in8, 3in24, DALY, NET55 and OCT55
- User defined: Ten 32-bit and one 24-Bit Programmable sequences

The following test sequences can be generated in Bulk mode

- PRBS: $2^{31}-1$, $2^{23}-1$

Error Insertion

OTN

- OTU-FAS, OTU-MFAS, OTU-BIP, OTU-BEI, Correctable FEC, Uncorrectable FEC, ODU-BIP, PM-BEI

Payload

- Bit (Pattern)

Injection Modes

- Single, Count (# of errors), Fixed Rates (1E-9 to 1E-3), and user-programmable rates

Alarm Generation

Physical Layer

- LOS

OTN

- OTU-LOF, OTU-LOM, OTU-AIS, OTU-IAE, OTU-BDI, OTU-BIAE, OTU-TIM, ODU-AIS, ODU-OCI, ODU-LCK, ODU-BDI, ODU-TIM, OPU-PLM

Generation Modes

- Continuous (manual), Count (0.1, 1, 10, 100 seconds)

OTN Overhead Analysis and Generation

Analysis – Decode and Display

Byte Decoding

- On-screen Decode

OTUk bytes in hexadecimal, binary or ASCII formats

- SM-TTI (SAPI, DAPI, User), SM-BIP, SM-BEI/BIAE, SM-BDI, SM-IAE

- GCC0 bytes

ODUK bytes in hexadecimal, binary or ASCII formats

- DMP and DMti

- PM-TTI (SAPI, DAPI, User), PM-BIP, PM-BEI, PM-BDI, PM-STAT

- ODU-TCM-ACT, TCMi-TTI (SAPI, DAPI, User), TCMi-BIP, TCMiBEI/BIAE, TCMi-BDI, TCMi-STAT

- GCC1, GCC2 bytes

- PCC/APS bytes

OPUk bytes in hexadecimal and binary formats

- JC1, JC2, JC3, (JC4, JC5, JC6), PSI, NJO

Reserved bytes

Generation - Programmable Bytes and sequences

OTU and ODU Trace Generation

- SAPI (15 characters)
- DAPI (15 characters)
- User (31 characters)
- Copy from received trace

TCMi Trace Generation

- SAPI (15 characters)
- DAPI (15 characters)
- User (31 characters)
- Copy from received trace

Set TCMi Status

- ODU-TCM-ACT (Binary and Hex)

Programmable Expected Traces

- OTU and ODU SAPI, DAPI, and User
- Copy from received trace
- Enable/Disable TIM monitor

Tandem Connection Monitoring (TCM)

TCMi Monitoring (1 through 6)

- LTC, AIS, OCI, LCK, BDI, BIAE, IAE; count
- IEC, BEI; count and rate

Trace Identifier Monitoring and Generation

- Programmable SAPI, DAPI and User traces
- Copy trace from RX
- Enable/Disable TIM monitoring

Ethernet over OTN (EoOTN)

Optional Mappings

- Direct mapping of 10G Ethernet payload into OTU1e or OTU2e, synchronous or asynchronous
- Direct mapping of 1G Ethernet payload into ODU0
- Direct mapping of Nx1.25G Ethernet payload into ODUflex

Ethernet Payload

- Layer 1 Unframed or Framed
- Layer 2, 3 and 4
- VLAN: Up to 3 tags
- MPLS: Up to 3 tags
- Layer 4: TCP or UDP

Ethernet Layer Testing*

- BERT
- RFC2544
- Throughput

Test Patterns (payload)

- PRBS: $2^{11}-1$, $2^{15}-1$, $2^{23}-1$, $2^{31}-1$
- Fixed: All 1s and All 0s
- User-defined 32 bit sequence
- Normal or Inverted

*Refer to the Ethernet Testing section for more details on Ethernet layer tests.

SDH/SONET Testing

Installation, commissioning, monitoring and maintenance of SDH/SONET and PDH/DSn networks is simplified thanks to a combination of intuitive features and powerful test functions. SDH signals are often compromised by various impairments in the multiplexing process therefore defining the type of anomaly or defect to isolate the network element or signal path causing the problem is crucial. Fast troubleshooting and comprehensive analysis of transmission problems can be performed using intrusive, non-intrusive and monitoring test modes. Novice users will benefit from the easy-to-use Auto-configuration and Tributary Scan test modes, while experienced users will appreciate the array of advanced features such as Overhead Monitoring and Byte Control, Pointer Test Sequences, Path Trace Generation, Tandem Connection Monitoring and lots more.

SDH/SONET signals can be used as physical layer or as OTN payloads, and can contain multiplexed PDH/DSn clients, providing all the flexibility to address complex test scenarios.

Key Features

- STM-64/16/4/1/0
- OC-192/48/12/3 and STS-3/1
- Bulk VC/STS/VT and multiplexed PDH/DSn payloads
- Overhead manipulation and monitoring
- Alarms/errors generation and analysis
- Service Disruption Time (SDT) and APS
- Round Trip Delay
- Tributary Scan
- Tandem Connection Monitoring
- Pointer Test Sequences
- Jitter and Wander Measurements

Test Interfaces

Optical

- STM-64/OC-192 9.953 Gbps
- STM-16/OC-48 2.448 Gbps
- STM-4/OC-12 622 Mbps
- STM-1/OC-3 155 Mbps
- STM-0/OC-1 52 Mbps

Electrical

BNC (75Ω unbalanced)

- STS-1/STM-0e, 51.84 Mbps, B3ZS
- STS-3/STM-1e, 155.520 Mbps, CMI

Receiver Sensitivity

51.840 Mbps (STS-1/STM-0e)

- Terminate: ≤ 10 dB (cable loss only)
 - Monitor (PMP): ≤ 26 dB (20 dB resistive, 6 dB cable loss)
- 155.520 Mbps (STM-1e)
- Terminate: ≤ 12.7 dB (coaxial cable loss only)

Operating Modes

Normal (terminal)

- The instrument terminates the line, serving as source and sink for the generated traffic
- Offers full access to Overhead and Payload alarms and error generation and monitoring

Payload Through (intrusive)

- Instrument retransmits the received Payload and allows access to Overhead manipulation
- Offers access to Overhead alarms and error generation as well as Payload monitoring

Line Through (transparent)

- Instrument regenerates and retransmits the entire received signal
- Offers minimal interaction with the test signal
- Provides full access to Overhead and Payload alarms and error monitoring

Out-of-Service Testing

Applications include:

- BERT (G.821)
- Tributary Mapping/de-Mapping
- Path/Section Trace Generation
- Bringing Into Service (M.2100)
- Mux Testing
- Round Trip Delay
- Pointer Test Sequences
- Jitter Measurement, Generation, MTJ, JTF
- Wander Measurements

In-Service Monitoring

Applications include:

- Optical Power and Frequency
- Tributary Scanning
- Performance Analysis per G.826, G.828, G.829, M.2101
- Pointer Analysis and Generation
- APS Measurement
- Tandem Connection Monitoring
- Overhead Byte Control and Decode
- Jitter and Wander Measurements

SDH Mappings

(According to ITU-T G.707)

- C-11 (Bulk/PRBS, unframed or framed DS1)
- C-12 (Bulk/PRBS, unframed or framed E1, asynchronous, bit or byte synchronous)
- C-3 (Bulk/PRBS, unframed, framed or channelized E3 or DS3) via AU-3 or AU-4
- C-4 (Bulk/PRBS, unframed or framed E4)
- C-4-4c (Bulk/PRBS)
- C-4-16c (Bulk/PRBS) • C-4-64c (Bulk/PRBS)

SONET Mappings

(According to Telcordia GR-253/ANSI T1.105)

- VT-2 (unstructured or framed E1)
- VT-1.5 (unstructured or framed DS1, asynchronous or float byte synchronous)
- STS-1 SPE (unstructured or framed E3 or DS3)
- STS-3c SPE (unstructured or framed E4)
- STS-12c SPE (Bulk) STS-48c SPE (Bulk)
- STS-192c SPE (Bulk)

Test Patterns

The following test patterns can be generated

- PRBS: 2³¹-1, 2²³-1, 2²⁰-1, 2¹⁵-1, 2¹¹-1, 2⁹-1, 2⁷-1, QRSS
- Fixed: 0000, 1111, 1010, 1100, 1in8, 2in8, 3in24, DALY, NET55 and OCT55
- User defined: Ten 32-bit and one 24-Bit Programmable sequences
- Mode: Normal or Inverted

Errors

Insertion

- SDH: FAS, B1, B2, MS-REI, B3, HP-REI, LP-REI, LP-BIP, and bit errors
- SONET: FAS, B1, B2, REI-L, B3, REI-P, REI-V, BIP-V, and bit errors
- Modes: Single, Count (# of errors), Fixed Rates (1E-9 to 1E-3), and user-programmable rates

Detection

- SDH: FAS, B1, B2, MS-REI, B3, HP-REI, LP-BIP, LP-REI, slips and bit errors
- SONET: FAS, B1, B2, REI-L, B3, REI-P, REI-V, BIP-V, slips and bit errors

Alarms

Generation

- SDH: LOS, LOF, MS-AIS, MS-RDI, RS-TIM, AU-LOP, AU-AIS, HPUNEQ, HP-PLM, HP-RDI, HP-TIM, TU-LOM, TU-LOP, TU-AIS, LPUNEQ, LP-PLM, LP-RDI, LP-RFI, LP-TIM, 2M AIS, 2M LOF, 2M RDI
- SONET: LOS, LOF, AIS-S, RDI-S, TIM-P, LOP-P, AIS-P, UNEQ-P, PLM-P, RDI-P, LOM-V, LOP-V, AIS-V, UNEQ-V, PLM-V, RDI-V, RFI-V, TIM-V, DS1-AIS, DS1-LOF, 2M-AIS, 2M-LOF, 2M-RDI, 45M-AIS, 45M-LOF
- Modes: Continuous (manual), Count (0.1, 1, 10, 100 seconds)

Monitoring and Detection

- SDH: LOS, LOF, OOF, RS-TIM, MS-AIS, MS-RDI, AU-AIS, AU-LOP, HP-UNEQ, HP-PLM, HP-TIM, HP-RDI, TU-LOM, TU-AIS, TU-LOP, LP-UNEQ, LP-PLM, LP-TIM, LP-RDI, LP-RFI
- SONET: LOS, LOF, OOF, AIS-S, RDI-S, TIM-P, LOP-P, AIS-P, UNEQ-P, PLM-P, RDI-P, LOM-V, LOP-V, AIS-V, UNEQ-V, PLM-V, RDI-V, RFI-V, TIM-V

Overhead Analysis and Generation

Network Architectures supported

- Linear (per ITU-T G.783)
- Ring (per ITU-T G.841)

Analysis – Decode and Display SOH/POH bytes in hexadecimal, binary or ASCII formats

- S1 synchronization status
- C2 HP/STS signal label
- J0 trace identifier (1, 16 or 64 bytes) in ASCII format
- J1 trace identifier (16 or 64 bytes) in ASCII format
- J2 trace identifier (16 or 64 bytes) in ASCII format
- K1, K2 APS Control
- V5 LP/VT signal label

Generation - Programmable Bytes RSOH/Section

- J0 trace: 1 byte hexadecimal, 16 byte ASCII with CRC-7 and 64 byte with CR+LF

MSOH/Line

- K1, K2 APS bytes per ITU-T G.783 and G.841
- S1 synchronization status message

HO-POH (VC-4, VC-3)/STS-POH (STS-N SPE, STS-1 SPE)

- J1 trace: 16 byte ASCII with CRC-7 or 64 byte ASCII sequence
- C2 signal label
- H4 Sequence/Multi-frame Indicator
- G1 (bit 5): End-to-end path status (RDI generation)
- K3 (bits 1-4) APS signaling

LO-POH (VC-3)/STS-POH (STS-1 SPE)

- J1 trace: 16 byte ASCII with CRC-7 or 64 byte ASCII sequence
- C2 signal label
- G1 (bit 5): End-to-end path status (RDI generation)
- K3 (bits 1-4) APS signaling

LO-POH (VC-12, VC-11)/VT-POH (VT-1.5, VT-2)

- V5 (bits 5-7) LP/VT signal label
- J2 trace: 16 byte ASCII with CRC-7 or 64 byte ASCII sequence
- K4 (bits 3-4) LP/VT APS signaling

Tributary Scan

Automatically scans VC-12, VC-11, VT-1.5 or VT-2 for errors, alarms and events using a sequential BER tests

Pointer Analysis and G.783 Test Sequences

Pointer movements monitoring and generation for SDH and SONET Monitor

- AU, TU, STS and VT pointer adjustments
- SS bits, LOP, New Data Flags (NDF)
- Current value, increments, decrements, sum, difference
- Tributary frequency offset (ppm of AU/TU or STS/VT)

Generation

- Pointer sequences: ITU-T G.783, Telcordia GR-253
- Pointer Types: AU, TU, STS, VT
- Single pointer, increment, decrement, or increment/decrement
- Sequence: Basic, Single Alternating, Regular Additive, Regular Cancel, Double Alternating, Burst, Transient Burst, 87/3, 87/3 Additive, 87/3 Cancel, Periodic Additive, Periodic Cancel
- Programming of SS bits
- Adjustments: Increment, Decrement, New Value
- Parameters: N, T1, T2, T3, T4

Tandem Connection Monitoring (TCM)

Generation and analysis of N1 (HP-TCM) and N2 (LP-TCM) bytes
Detection, display and analysis of events

- UNEQ, TC-AIS, TC-ODI, TC-IEC, TC-REI, TC-OEI, TC-LTC, TC-RDI

PDH/DSn Testing

While telecommunications network technologies have evolved to include long-distance high-capacity OTN, SDH/SONET or Ethernet trunks, PDH/DSn links and clients are frequently retained for voice, access, service delivery and for other economic reasons. As such, testing PDH/ DSn interfaces, payloads and services continue to play an important role in test and measurement.

This test set provides PDH/DSn interfaces, payload generation, access and testing capabilities for 140 Mbps (E4), 45 Mbps (DS3), 34 Mbps (E3), 2 Mbps (E1), 1.544 Mbps (DS1), down to N×64 and N×56 kbps. PDH/DSn clients can be multiplexed into a higher PDH/DSn signal, mapped into SDH/SONET containers, and then mapped into OTN, giving it the flexibility to address complex test scenarios.

PDH/DSn Interfaces

Electrical

- RJ-48 (120Ω) or Bantam (100Ω) balanced
- DS1, 1.544 Mbps, AMI & B8ZS, 100Ω balanced
- E1, 2.048 Mbps, HDB3 & AMI, 120Ω balanced
- G.703 Codirectional, 64 Kbps, 120Ω balanced BNC (75Ω unbalanced)
- E1, 2.048 Mbps, HDB3 & AMI
- E2, 8.448 Mbps, HDB3
- E3, 34.368 Mbps, HDB3
- DS3, 44.736 Mbps, B3ZS
- E4, 139.264 Mbps, CMI

Compliant to ITU-T G.703, G.823, G.824, G.772 and ANSI T1.102

Receiver Sensitivity

- 1.544 Mbps (DS1)
 - Terminate: ≤ 26 dB (cable loss only) at 0 dB DSX Tx
 - Monitor (PMP): ≤ 26 dB (20 dB resistive, 6 dB cable loss)
 - Bridge: ≤ 6 dB (cable loss only)
 - Line Equalizer function provides increased dynamic range to support for LBO < -7.5 dB
- 2.048 Mbps (E1)
 - Terminate: ≤ 6 dB (cable loss only)
 - Monitor (PMP): ≤ 26 dB (20 dB resistive, 6 dB cable loss)
 - Bridge: ≤ 6 dB (cable loss only)
 - Line Equalizer function provides increased dynamic range to support for LBO < -7.5 dB
- 8.448 Mbps (E2)
 - Terminate: ≤ 6 dB (cable loss only)
 - Monitor (PMP): ≤ 26 dB (20 dB resistive, 6 dB cable loss)
- 34.368 Mbps (E3)
 - Terminate: ≤ 12 dB (cable loss only)
 - Monitor (PMP): ≤ 26 dB (20 dB resistive, 6 dB cable loss)
- 44.736 Mbps (DS3)
 - Terminate: ≤ 10 dB (cable loss only)
 - Monitor (PMP): ≤ 26 dB (20 dB resistive, 6 dB cable loss)
- 139.264 Mbps (E4)
 - Terminate: ≤ 12 dB (coaxial cable loss only)

Operating Modes

Terminate, Monitor, Bridge (E1 & DS1)

Signal Structure

1.544 Mbps (DS1)

- Unframed or Framed SF (D4), ESF per ANSI/Telcordia standards
- Fractional test signal in N x 64 kbps or N x 56 kbps, where N=1 to 24

2.048 Mbps (E1)

- Unframed or Framed with/without CRC per ITU-T G.704 (PCM30, PCM30C, PCM31, PCM31C)
- Fractional test signal in N x 64 kbps, where N=1 to 30/31

8.448 Mbps (E2)

- Unframed or Framed according to ITU-T G.742

34.368 Mbps (E3)

- Unframed or Framed according to ITU-T G.751

44.736 Mbps (DS3)

- Unframed or Framed M13 & C-Bit Parity per ITU-T G.752/G.704

139.264 Mbps (E4)

- Unframed or Framed per ITU-T G.751

Test Patterns

The following test patterns can be generated

- PRBS: $2^{31}-1$, $2^{23}-1$, $2^{20}-1$, $2^{15}-1$, $2^{11}-1$, 2^9-1 , 2^7-1 , QRSS
- Fixed: 0000, 1111, 1010, 1100, 1in8, 2in8, 3in24, DALY, NET55 and OCT55
- User defined: Ten 32-bit and one 24-Bit Programmable sequences
- Mode: Normal or Inverted

Errors

Insertion

- 1.544 Mbps (DS1): Code, FAS, Bit, Frame, CRC
- 2.048 Mbps (E1): Code, FAS, CRC, REI/EBIT, Bit errors
- 8.448 Mbps (E2): Code, 8M FAS, 2M FAS, 2M CRC, 2M RDI, Bit errors
- 34.368 Mbps (E3): Code, 34M FAS, 8M FAS, 2M FAS, 2M CRC, 2M RDI, Bit errors
- 44.736 Mbps (DS3): Code, FAS, MFAS, P/C-Parity, Bit errors
- 139.264 Mbps (E4): Code, FAS, Bit errors
- Modes: Single, Count (# of errors), Fixed Rates (1E-9 to 1E-3), and user-programmable rates

Measurement

- 1.544 Mbps (DS1): Code, FAS, Bit, Frame, CRC
- 2.048 Mbps (E1): Code, FAS, CRC, REI/EBIT and Bit errors
- 8.448 Mbps (E2): Code, FAS, Bit errors
- 34.368 Mbps (E3): Code, FAS, Bit errors
- 44.736 Mbps (DS3): Code, FAS, MFAS, P/C-Parity, Bit errors
- 139.264 Mbps (E4): FAS

Alarms

Generation

- 1.544 Mbps (DS1): AIS, yellow, idle, LOS, LOF
- 2.048 Mbps (E1): LOS, AIS, LOF, RDI
- 8.448 Mbps (E2): 8M AIS, 8M LOF, 8M RDI, 2M AIS, 2M LOF, 2M RDI
- 34.368 Mbps (E3): 34M LOS, 34M AIS, 34M LOF, 34M RDI, 8M AIS, 8M LOF, 8M RDI, 2M AIS, 2M LOF, 2M RDI
- 44.736 Mbps (DS3): LOS, LOF, OOF, AIS, Parity
- 139.264 Mbps (E4): LOS, AIS, LOF, RDI

Measurement

- 1.544 Mbps (DS1): AIS, yellow, idle, LOS, LOF, LSS
- 2.048 Mbps (E1): LOS, AIS, LOF, LOMF, RDI, and LSS
- 8.448 Mbps (E2): LOS, AIS, LOF, RDI, and LSS
- 34.368 Mbps (E3): LOS, AIS, LOF, RDI, and LSS
- 44.736 Mbps (DS3): LOS, LOF, OOF, AIS, Parity, LSS
- 139.264 Mbps (E4): LOS, AIS, LOF, RDI
- Modes: Continuous (manual), Count (0.1, 1, 10, 100 seconds)

Measurement Functions

Test Results

Error count, ES, %ES, SES, %SES, UAS, %UAS, EFS, %EFS, AS, %AS, and rate for all events: errors, alarms and pointer events

Performance Analysis

Measurements according to:

- ITU-T G.821: ES, EFS, SES and UAS with HRP 1% to 100%
- ITU-T G.826: EB, BBE, ES, EFS, SES, UAS; HRP of 1% to 100%
- In Service Measurement (ISM) using B1, B2, B3, FAS, CRC or Code (E1)
- Out of Service measurement (OOS) using bit errors (Test Sequence Error)
- ITU-T G.828: ES, EFS, SES, BBE, SEP, UAS with HRP 1% to 100%
- ITU-T G.829: ES, EFS, SES, BBE, UAS on RSOH (B1), MSOH (B2) or TSE
- ITU-T M.2100: ES, EFS, SES, UAS with HRP 1% to 100%
- User defined thresholds for Maintenance (MTCE) and Bringing into Service (BIS) objectives
- ITU-T M.2101: ES, EFS, SES, BBE, SEP, UAS with HRP 1% to 100%
- User defined thresholds for Maintenance (MTCE) and Bringing into Service (BIS) objectives. In service measurements on both near and far ends of path using TSE, HP-BIP/P-BIP (B3), MS-BIP/L-BIP (B2), RS-BIP/S-BIP (B1) and LP-BIP/V-BIP (V5)

G.703 64k Codirectional Testing Option

This legacy interface still plays a role in today's communication, supervisory control and data acquisition applications. It is often used by utilities' telemetry and teleprotection equipment.

Interfaces

- RJ48 (120Ω) , Bantam (100Ω)
- Available RJ48 to 3-pin Banana converter

Transmit Clock

- Internal, External, Received
- Frequency offset generation to ±150.00 ppm

Measurements

- Bit, Code, LOS, AIS, pattern loss (LSS) with Histogram and Bar Graph representation
- G.821 performance evaluation
- Signal level, data rate and offset
- Time-stamped Events Log
- Round-trip Delay

Error and Alarm Generation

- Bit, Code, LOS, AIS

DSn Functions*

Pulse Mask Analysis

PDH/DSn signals may fail pulse shape requirements due to interference, excessive cable length, improper impedance, open cable branches or poor transmitter characteristics. In such cases, G.703 Pulse Mask compliance verification is very useful in diagnosing related physical layer problems.

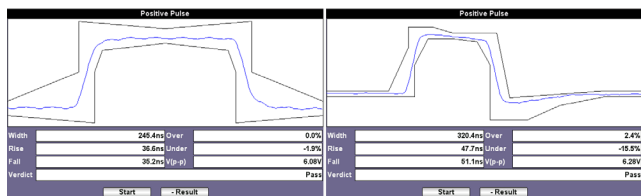

PDH

- Bit rates: 2.048 Mbps (E1) and 34.368 Mbps (E3)
- Conformance Mask: ITU-T G.703

DSn

- Bit rates: 1.544 Mbps (DS1) and 44.736 Mbps (DS3)
- Conformance Masks: ITU-T G.703, ANSI T1.102, T1.403, T1.404

Mode: Non-Intrusive

Display: Pulse shape graph with Conformance mask verification (Pass/Fail)

Parameters: Width, Rise/Fall time, Overshoot/Undershoot

E1/DS1 VF Measurements Option

The Voice Frequency (VF) option is a basic diagnostic tool to install, verify and troubleshoot voice circuits. Digital to analog conversion tests are performed by inserting/measuring tones with user defined frequency and level on selected sub-rate channels.

A microphone/headset jack enables Talk/listen capability on a selected timeslot while a powerful function allows VF decoding at all PDH/DSn and SDH/SONET rates

Codec: μ -Law or A-Law

Programmable ABCD

- Manual edit AB, ABCD or ON-HOOK, OFF-HOOK, WINK for DS1, and IDLE, SEIZE for E1

Independent Time Slot channel selection for TX and RX

- E1 channel: 1 -15, 17-31, 1 to 31
- DS1 channel: 1 to 24

Voice (Talk)

- VF drop/insert via headset
- 2.5 mm TRS audio jack for headset
- Listen to the audio channel in selected timeslot

Tone Generation and Measurement

- Transmit Frequency: 50 to 3950 Hz
- Transmit Level: -60 to 3 dBm

Results

- AB/ABCD bits monitor
- View Received Data in selected T/S
- Measure signal frequency and level in selected timeslot

DS1 and DS3 Auto-Monitor

Quickly auto-configures to the received signal and runs a health check. Provides a summary screen with all alarm indications, frequency, signal level, BPV/code errors, FBE, clock slips Histogram and bar graph representation of errors and alarms Channelized DS3 support with selectable DS1 channel status

DS1 Loopback Commands

Enhanced DS1 Loopback command generation enable users to singlehandedly test DS1 links by activating automated loopbacks in the desired network elements.

In-band:

- CSU, NIU FAC1, NIU FC2 ESF Facility Data Link (FDL) Control

Line and payload HDSL Abbreviated (short)

- From Network (CO) or CPE
- NLOC, NDU1, NDU2, NREM

HDSL Long (In-band)

- From Network (CO) or CPE
- 2-wire and 4-wire
- HTU-C, H4R1, H4R2, H4R3, HTU-R
- Arm, Query Loop, Time-out override, Loopback Query, Loop Up, Loops down, Disarm commands
- Detailed confirmation messages

User Defined codes

- Programmable codes up to 16 bits
- Programmable time out

DS1 Multi-BERT™

Bring into service and troubleshoot DS1 links quickly by automatically generating different test patterns in a sequential BER test. Since certain test patterns can help identify and test for specific problems or behaviors, the test sequence can be customized with specific test patterns and timings to target specific test scenarios, like checking for proper line coding settings, framing, or clock recovery.

- Sequential BER testing with up to eight test patterns (any standard test pattern in any order)
- Single cycle and Continuous operations
- Individual pattern timing up to 3599 seconds (1 hour)
- Bit, Code, FBE, ES, and total test time report, per pattern and totals
- Monitors signal frequency, level (dB and dBm) and CRC error count

**These features are only available in the USA user interface mode*

ISDN PRI Testing

The ISDN option provides functionality necessary for testing and troubleshooting DS1 or E1 Primary Rate connections like SIP trunking services. Operating in TE or NT modes, the unit is able to setup and receive ISDN calls with user-defined parameters including call control protocol, called number and related facilities.

Protocol functions feature detailed signaling statistics, message monitoring, capture and decode. With these capabilities, analysis of international and national ISDN, and other access protocols is possible.

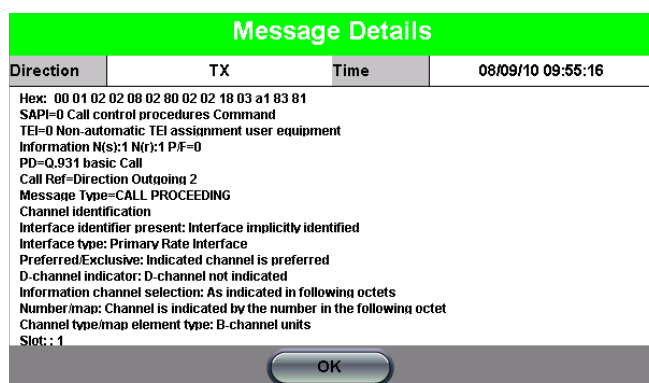

TE and NT Emulation

- Place/Receive voice and data calls
- D-channel monitor with full decode: Layer 2 (Q.921) and Layer 3 (Q.931)
- 23B+D, 30B+D

Protocols

- DS1: National ISDN, AT&T, Nortel DMS
- E1: ETSI (Euro – ISDN)
- Bidirectional protocol capture and decode

Voice calls talk and listen via headset

In-band DTMF generation

Supports multi-rate N x 64k data calls

Parallel and sequential multi-call channel test

- All calls to a single number
- Multiple numbers from a programmable list

Supplementary Services Test

Automatically tests the provisioning of CLIP, CLIR, COLP, CFU, CFB, CFNR, SUB, MSN, DDI, HOLD, UUS, TP, AOC-S, AOCD, AOCE, MCID, CUG

Common Functions & Measurements

Service Disruption and APS Testing

Service disruption time (SDT) measurements are integrated to the regular BER tests, supporting multi-layer sensor monitoring and events table for OTN, SDH/SONET and PDH/DSn

OTN Sensors

- LOS, OTU-AIS
- OTU-LOF, OTU-LOM, OTU-IAE, OTU-BDI, SM-BIAE, ODU-AIS, ODU-LCK, ODU-OCI
- FAS, MFAS, OTU-BIP, OTU-BEI, ODU-BIP, ODU-BEI

SDH Sensors

- LOS, LOF, FAS
- B1, MS-AIS, MS-RDI, MS-REI, B2, AU-AIS, AU-LOP, B3, HP-RDI, HP-REI, TU-AIS
- PDH payload-related triggers
- LSS

SONET Sensors

- LOS, LOF, FAS
- S-BIP, AIS-L, RDI-L, REI-L, L-BIP, AIS-P, LOP-P, P-BIP, RDI-P, REI-P, AIS-V
- PDH payload-related triggers
- LSS

PDH (E1) Sensors

- E1-LOF, E1-AIS
- LSS

Pass/Fail range: 15 to 200 ms

Gate Time: 20 to 4000 ms

SDT Results Summary

- Last Service Disruption Time
- Longest Service Disruption Time
- Shortest Service Disruption Time
- Time stamps resolution: 10 μ s
- Total number of Service Disruptions events observed

Disruption Events Table

- Tracks every Service Disruption event for all layers
- Time stamp with 10 μ s resolution
- Duration with 10 μ s resolution
- Individual Pass/Fail Verdicts
- Tracks individual sensor events that occurred during the disruption period with time stamp and duration (10 μ s resolution)

APS Testing

- SDH/SONET APS Byte (K1/K2) sequence capture and decode

Auto Configuration

Auto configure simplifies instrument setup when properties of the incoming test signal are unknown. This feature allows novice users to start performing measurements quickly.

- Available for SDH, PDH, SONET and DSn signals
- Identification of received signal - instrument configuration based on network type, bit rate, line coding, framing, mapping, and test pattern

Signal Level and Frequency Measurement

Available for Optical and Electrical Interfaces

Signal level

Optical power in dBm and Loss/Saturation graph
Electrical level in Volts peak-to-peak, dB and dBm

Frequency (Line and Payloads)

Resolution: 1 bit/s (bps)

Frequency Offset

Resolution: 0.1 ppm Current, Minimum and Maximum

Clock Slips (E1 and DS1)

Round Trip Delay

(Available for all interfaces & mappings)

Measurement Range: 1 μ s to 10 seconds

Resolution: \pm 1 μ s or 1 U.I.

Event Logging

Date and time stamped records of all error and alarm events occurred during a test, presented in tabular format

Histograms

Histogram: Simultaneous display of Errors and Alarms versus time for sequence of events correlation

Bar Graph: Individual Error, Alarm severity and power level versus time

Resolution: Seconds, minutes, hours and days

Soft LED Indicators

Summary indicators for Signal, Framing, Pattern sync and Errors/Alarms are always visible within the test application

Dual LED row for Ethernet in EoOTN test mode

Display historical events and conditions

History reset function

- Clears the LED reminder without affecting the measurement counters

Detailed multi-layer Alarm and Error status summary, each with direct access to their respective counters

Fibre Channel

Key Features

- Full line rate traffic generation and analysis up to 16G
- Primitive Sequence Protocol support
- Flow control support with Buffer-to-Buffer credits
- FC-1 and FC-2 BERT and Throughput
- RFC2544: Throughput, Latency, Frame Loss, and Back-to-Back frames tests
- FC-2 Smart Loop mode
- Service Disruption Measurement
- FC-2 Frame Header configuration
- Test traffic shaping: constant, ramp, and burst
- Frame Length configuration up to 2148 bytes

Throughput and Bit Error Rate Test (BERT)

The Fibre Channel protocol specifies a maximum allowable Bit Error Rate (BER) of $\leq 1 \times 10^{-12}$ that must be achieved. The test set allows the user to stress FC-1 and FC-2 network layers to ensure accurate benchmarking.

For FC-1, frequency fluctuations, transceiver noise and phase jumps are tested using CRPAT, CSPAT, and CJPAT patterns. Data dependency and behavior of network components are checked with PRBS patterns, sequence number tracking, and time stamping to calculate frame loss, round trip delay, and other performance metrics.

RFC2544 Benchmarking

Based on the Ethernet test methodology, the RFC2544 routine has been adapted to Fiber Channel circuits where flow-control and buffer verification is important. The feature checks throughput and round trip delay at various buffer sizes to verify optimal buffer size and best possible link performance.

Fibre Channel Interfaces

Dual 1/2/4/8/10/16G Fibre Channel SFP+ optical Ports: LC connectors

Fibre Channel Rates

1.0625 Gbps, 2.125 Gbps, 4.25 Gbps, 8.5 Gbps, 10.52 Gbps, and 14.03 Gbps

Modes of Operation

Terminate, Loopback

Fibre Channel Topology

Point-to-Point

Primitive Sequence Protocols

Link initialization, link rest, link failure

Flow Control

Buffer-to-Buffer Credit Configuration: 1-65535

Traffic Generation

FC-1 (with SOF and EOF frame delimiters) and FC-2 Frames

Class 3 Service frames

Scrambling/Descrambling (8.5 Gbps only)

Configurable Header fields

Configurable EOF (EOF_t, EOF_n), and SOF (SOF_i3, SOF_n3, SOF_f)

Traffic Shaping: constant, ramp, burst

Frame Length Configuration: 2148 bytes maximum

RFC2544 Compliance Testing

Automated tests compliant with RFC2544 with configurable threshold values for Throughput and Round Trip Delay (Latency) and maximum transmit bandwidth settings
Throughput, Latency, Frame Loss, and Back-to-Back (burst) tests
Frame sizes: 64, 128, 256, 512, 1024, 1280, and 2000 bytes including 2 user configurable frames

Bit Error Rate Testing

NCITS-TR-25-1999 Patterns (FC-1): CRPAT, CSPAT, CJPAT

PRBS Patterns (FC-2): $2^{31}-1$, $2^{23}-1$, $2^{15}-1$, $2^{11}-1$, normal and inverted selections, and user defined patterns

Error Injection: Bit and CRC

Loopback Mode

FC-1

FC-2 (Layer 2): swaps the destination and source IDs (D_ID and S_ID)

Key Measurements

Optical power levels: transmit and receive optical levels in dBm

Error Measurements: Bit error count, BER, symbol, FCS/CRC, oversize, undersize, frame loss (count and %), out of sequence frame count

Alarm Detection: LOS, pattern loss, service disruption

Traffic Statistics: bandwidth utilization, data rate, frame count, byte count, frame size distribution, buffer-to-buffer credit count, RR_RDY count, frame loss count and round trip delay

Rates: line rate, framed rate, data rate, frames per second rate

Delay (min, max, avg, current): round trip delay, frame arrival delay

CPRI & OBSAI Testing

Traditional deployment of the base station functions are co-located with the radio tower at the base of the antenna or basement of a tall building.

The Common Public Radio Interface (CPRI) and Open Base Station Architecture Initiative (OBSAI) protocols introduce a centralized model where one REC (Radio Equipment Controller) can manage many REs (Radio Equipment). The REC can be physically located far from radio towers in a centralized indoor and temperature controlled location. The CPRI/OBSAI optical link between REC and RE allows long distances without loss.

Simplified RE function makes field elements more compact, easier to install, and therefore increases the number of possible sites. Further Capex and Opex improvements are possible by having one REC manage many towers, and increased deployment flexibility to add new cell sites.

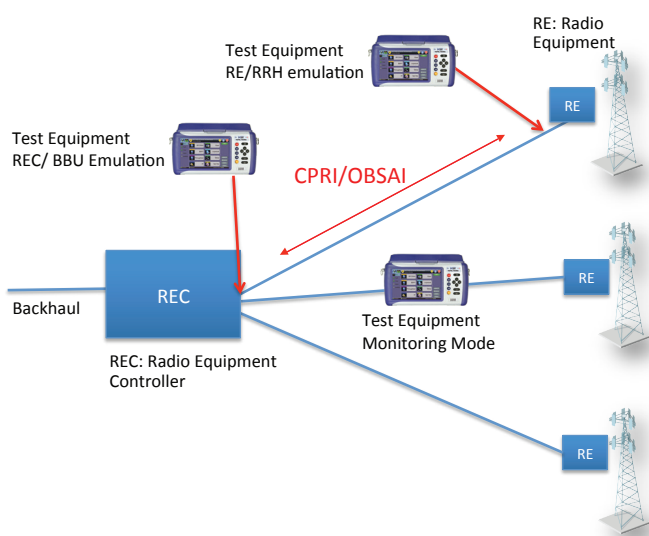

BERT

Test network performance with Layer 2 Framed BERT with PRBS stress pattern. Verify BER, code violations, alarms and service disruption testing. CPRI Layer 2 testing includes REC or RE emulation, BER traffic generation, control words decode and frame capture capabilities to troubleshoot interoperability, transport or RF performance issues.

CPRI Rates

• CPRI 9	12.1651 Gbps
• CPRI 8	10.137 Gbps
• CPRI 7	9.8304 Gbps
• CPRI 7A	8.110 Gbps
• CPRI 6	6.144 Gbps
• CPRI 5	4.9152 Gbps
• CPRI 4	3.072 Gbps
• CPRI 3	2.4576 Gbps
• CPRI 2	1.2288 Gbps
• CPRI 1	614.4 Mbps

Latency Measurement

Highly accurate latency measurements ensures that CPRI traffic between controller and the radio equipment stays below standard specifications.

CPRI Layer 2

REC/BBU Emulation and RE/RRH Emulation

Error Injection: Bit, Code Violation

Alarm Injection: LOS, LOF, SDI, RAI, RLOS, RLOF

Error measurements: Bit, BER, CV, CV Rate, Pattern Loss

Alarms detection: LOS, LOF, HLOF, BLOF, SDI, RAI, RLOS, RLOF

Latency measurement

Service Disruption Test

Frequency and Offset (current, min, max)

TX/RX Hyperframes and NodeB Frames counters

Configurable HDLC and Ethernet C&M channels

Control Words decode

CPRI Hyperframes capture

Bi-directional Monitor Mode

Bi-directional traffic analysis and monitoring between RE and REC, and hyperframe capture

General

Environmental

Operating temperature	0 to 45°C (32 to 113°F)
Storage temperature	-20 to 70°C (-4 to 158°F)
Humidity	5% to 90% non-condensing

Test Set Weight

RXT-3400 module	1.06 kg (2.3 lb)
RXT-1200 platform	1.32 kg (2.9 lb)
9-cell Li-ion battery	0.54 kg (1.2 lb)

ROHS compliant and Lead Free per Directive 2002/95/EC