

Battery Analyzer

WENS 900C

User Manual



Table of Contents

Notes for Safe Operations 5



1. Introduction

1.1 Battery Health (Deterioration) Judgment 8
1.2 Description..... 8
1.3 Special Features..... 10
1.4 Description of each part and functions..... 12
1.5 Dimensions and Weight..... 15

2. Initial Setting before use

2.1 Battery Install and Replacement..... 15
2.2 Insert Test Probe..... 16
2.3 Power ON/OFF  18
2.4 Timer function 19
2.5 Back Light Display  19

3. Measurement (Resistance.Voltage.Current.Temp)

3.1 Check Point before Measurement..... 21
3.2 “ 0” Adjustment Method and Procedure 21
3.3 Measurement..... 25
3.4 Auto Hold – Auto Record  29
3.5 Data Hold  31
3.6 Judgment of Battery Deterioration 32

4. Limit (Comparator)

4.1 Limit judgment function	32
4.2 Limit function Operation Procedure	34
4.3 Judgment of Limit.....	35
4.4 Limit function – Beeper Set Up	38
4.5 Release Limit function	38

5. Record

Record

5.1 Record function	39
5.2 Record Diagram	39
5.3 Record Display	40
5.4 Unit Set Up	41
5.5 Address Set Up	43
5.6 A-REC (Auto Recording)	44
5.7 Replay of Recorded Data	45
5.8 Erase of Recorded Data	46
5.9 How to Input Reference (Initial) Data.....	47
5.10 Move of Recoded Data.....	49

6. Analyzer

Analyzer

6.1 Recall	50
6.2 Data Table.....	51

6.3 Trace (Trend Curve Analysis) and Fitting (Battery Change Estimation)	54
--	----

7. SOC (State of Charging) Capacity

7.1 SOC measurement	58
7.2 SOC Recall	59



8. Capacity Capacity

8.1 Preparation of Capacity measurement	61
8.2 Capacity measurement	63
8.3 Recall of Capacity measurement record	64
8.4 ZOOM	65
8.5 Removal of Measurement Record	66

9. Data Base (D/B) D/B
User

9.1 Saving Data Base	68
9.2 Data Base function	68
9.3 Recall DB Application at limit	68
9.4 D/B Application	69
9.5 Input and Erase of DB	69

10. Auxiliary Functions

10.1 Auto Power Off	70
10.2 Low Battery Warning	72
10.3 User 	72
10.4 HELP 	75
10.5 Others.....	76

11. PC Interface Program

11.1 Description.....	78
11.2 Suggested Operation Environments	78
11.3 Connection between Analyzer and PC.....	78
11.4 PC Interface Software Installation Procedure.....	79
11.5 Removal of Software.....	82
11.6 How to use Software	82
11.7 How to finish Software	93

12. Specifications

12.1 General Specifications	93
12.2 Electrical Specifications	94
12.3 Accessories	97

13. Maintenance

13.1 General Maintenance.....	97
13.2 Fuse Replacement	98
13.3 Battery Replacement	98
13.4 When Unit is not working	99
13.5 Test Probe Pin Replacement	99
13.6 Cleaning.....	100
13.7 Scrap	100

Notes for Safe Operation

Please review following items regarding safety in order to prevent harm or damage to the Battery Analyzer or any connecting system. To prevent any potential harm, operate the Analyzer according to the instructions in the manual. (Refer Battery Analyzer as Analyzer hereafter)



The Analyzer is designed and tested according to International Safety Standard IEC 61010-1 before delivery.

Any improper or incorrect measurement method may cause personal injury and damage to the Analyzer

[Safety Terms and Symbol]

Technical Terms which appear in this manual are listed below.

Before use the Analyzer, please read following Safety Symbol carefully

 : User should read  making area in the Manual and need pay attention.

User should operate the Analyzer after read the manual where  marking on the Analyzer. .

 : DC (Direct Current or Voltage)

 : Fuse

 : Grounding Terminal

: WARNING

WARNING statements identify conditions or practices that could result in injury or loss of life.

: CAUTION

CAUTION statements identify conditions or practices that could result in damage to the product or property.

Operation Environment

- Temperature, Relative Humidity Range: 0~40 °C, max 80%rh
(Non- Dew condition)
- Guaranteed Accuracy Temperature, Relative Humidity Range
23±5 °C, max 80%rh (Non Dew condition)
- Please do not use Analyzer for a long time at following environments where
Analyzer may cause trouble and accident.
 - ☞ Under direct sunlight
 - ☞ High Temperature
 - ☞ Where Water flow
 - ☞ High Humidity and Dew
 - ☞ Dusty
 - ☞ Explosion Gas
 - ☞ Strong Electromagnetic field
 - ☞ Nearby Electronic Objects
 - ☞ Machine or System shaking

Caution before use Analyzer

- Check whether the Analyzer is good operation condition during delivery to user. If
any problem found, immediately inform to the supplier whether the Analyzer
purchased.
- Check test lead-covered wire is not peel off or any inside metal is exposed. If
any damaged test lead may cause Electric Shock and should replace with good
test lead.
- To prevent Electric Shock, do not use Analyzer when the Cover Case of the
Analyzer is opened.
- To prevent damage on the Analyzer, avoid drop to the ground or severe impact
during moving or handling.

Caution when Measurement

To prevent Electric Shock, please pay following caution

- When measure Internal Resistance (Impedance), Battery Voltage should not exceed 100V DC. When measure Voltages only, Input Voltage should not exceed 300V DC.
- Do not measure AC Voltages
- Proper connection of Battery Test Probes(for Internal Resistance, Voltages), CT -DC Current Adapter (for low Currents), Temperature Socket, USB Lead (for PC Communication)
- Special attention on Spark when Test Probes contact Battery. Can catch fire if area is with inflammable gas.

Caution on Test Probes

- For Safe and Accurate measurements, use the Battery Test Probes supplied with the Analyzer.
- To prevent fault from breaking of wire, do not pull or fold the cable of Test Probe.
- Tip of Test Probe is sharp, be careful not to hurt from it.
- To prevent damage on the tip, do not press the tip by force.

1. Introduction

1.1 Battery Health (Deterioration) Judgment

To judge Battery Deterioration, measure and manage the internal resistance of the battery being installed or new replacement battery periodically.

In general, internal resistance value increased by 1.5 ~ 2 times from initial value (reference value) when battery is deteriorated

[Judgment of Health (Deterioration)]

- In case Lead Storage Cell (Lead-Acid battery), Warning status starts when internal resistance value increased by 1.5 from initial internal resistance value. Deterioration standard is little different by manufacturer of Battery
- Even though Same Capacity battery, Initial Internal Resistance value of Battery is different from Type and manufacturer.
- “WARNING”, “FAIL” level of Internal Resistance is little different by manufacturer.

[Recommendation of Battery Replacement Time]

Periodically measure Impedance, Voltages and Temperature of the battery.

In management and save the measurement data which recommends the Time of Battery Replacement.

[Judgment of Battery Replacement Time]

- Based on the specifications of the battery in management when installed, Trend of changing data from every measurement displayed in graphic.
- Right Timing of replacement of Battery may be estimated and displayed on LCD display backed by accumulated measurement data .

1.2 Description

- The Analyzer designed for measuring the internal resistance, open circuit voltage and +/- Terminal temperature of secondary batteries including lead storage cells, nickel-cadmium batteries, lithium-ion batteries and nickel-metal hydride batteries.

[Analyzer]



- Data from measurements may transfer to computer through USB cable. The Measurement Data to computer can be saved or edited to analyze or manage of the battery health (deterioration) at computer.
- May input or remove of reference data of the battery in management through computer.

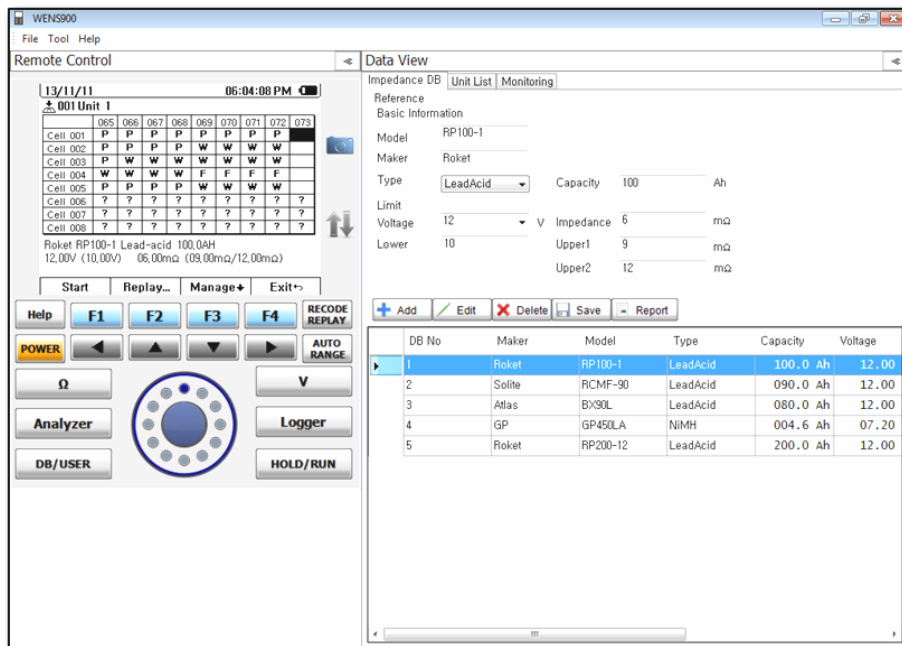

[PC Interface]

1.3 Special Features

Measurement Cells while loaded at UPS system.

The Analyzer applies high technology on AC Resistance measurement while UPS system is loaded.

Accurate Measurement

AC four-terminal method to measure the internal resistance by eliminating, lead resistance and contact resistance to get the accurate results.

Internal Resistance, Voltage, Temperature measurements (simultaneously).

For measure Temperature, require USB type temperature probe.

For measure Current, require external Adapter.

Comparator

It has 99 sets of composite comparator function, which can be set at resistance and voltage value (Limit) to get the reliable detection of battery deterioration. LCD displays PASS, WARNING, FAIL results and beeper for "Warning and Fail" results.

SD High Capacity Memory

All measurement data (up to 7,530,000 data) including Resistance, Voltage, Temperature, Currents, Comparator result can be saved at SD memory inside of Analyzer. This capacity allows to stored data as

Unit (Bank) : Max 251 (including 1 Auto Unit No : 000 - Reference D/B not registered and Open Unit No : 001 ~ 250 : Reference D/B registered)

Cell : Max 300 cells per unit

Slot : 100 times (measurement)per Cell.

Auto Saving

If User set "AUTO HOLD" measurement data is automatically saved at internal memory. Maximum 300 Cell data can be saved in order. The saved data can be transferred to assigned address of memory or can be removed.

PC Interface - Function Control through PC

Measured Data can be down-load to PC and can be saved or edited at PC.

The Analyzer function can be controlled or up-load DB data through PC.

Pin Type Test Probe

Tip of Probe may access into 5 mm hole which allows Battery Electrodes measurement without opening the Battery Electrodes Cover.

Measurement Data Average



When in "Auto Hold " mode, maximum 100 measurement data can be average and display at upper left of LCD screen of the Analyzer.

















Very practical function when there is change of measurement value.

The Average Data cab be cleared by pressing F3 (AVG Clear) key.



1.4 Description of each part and functions



- ① Impedance, Volt measurement Input: *Connect plug of the (+) RED test probe.*
- ② Impedance, Volt Measurement Input: *Connect plug of the (-)BLACK test probe.*
- ③ LCD display.
- ④ Help 
- ⑤ Power : *Power ON/OFF*

- ⑥ LCD Back Light 
- ⑦ Auto/Manual Ranging 
- ⑧ Up/Down/Left/Right direction Function    
- ⑨ Menu Key(F1~F4)    
- ⑩ Impedance (Internal Resistance) 
- ⑪ Record 
- ⑫ 
- ⑬ Capacity  key for V.A. SOC. Capacity measurement.
- ⑭ Data Base / User key 
- D/B key for short time to enter. User key longer than 2 seconds to enter.*
- ⑮ Data HOLD / Auto HOLD key: 
- Data Hold: press the key for short time to enter or exit.*
Auto Hold: press the key longer than 2 seconds to enter or exit
- ⑯ Encoder Rotary switch: Resistance Range selector switch.
- Enter Key when reset any function or confirm to conduct the function, push down*
- ⑰ DCA, SOC, Capacity measurement input jack: Connect with
*DCA current Probe (CT) * (DC 40A/400A range).*
- ⑱ USB interface: PC interface connector.
- ⑲ AC adaptor input jack: Connects to the AC Power adapter

[Note]

  keys are Dual function keys.

Press Short Time to enter Upper Line functions (HOLD, D/B , Analyzer) and press long time (longer than 2 seconds) to enter Under line functions (AHOLD-AREC, User)

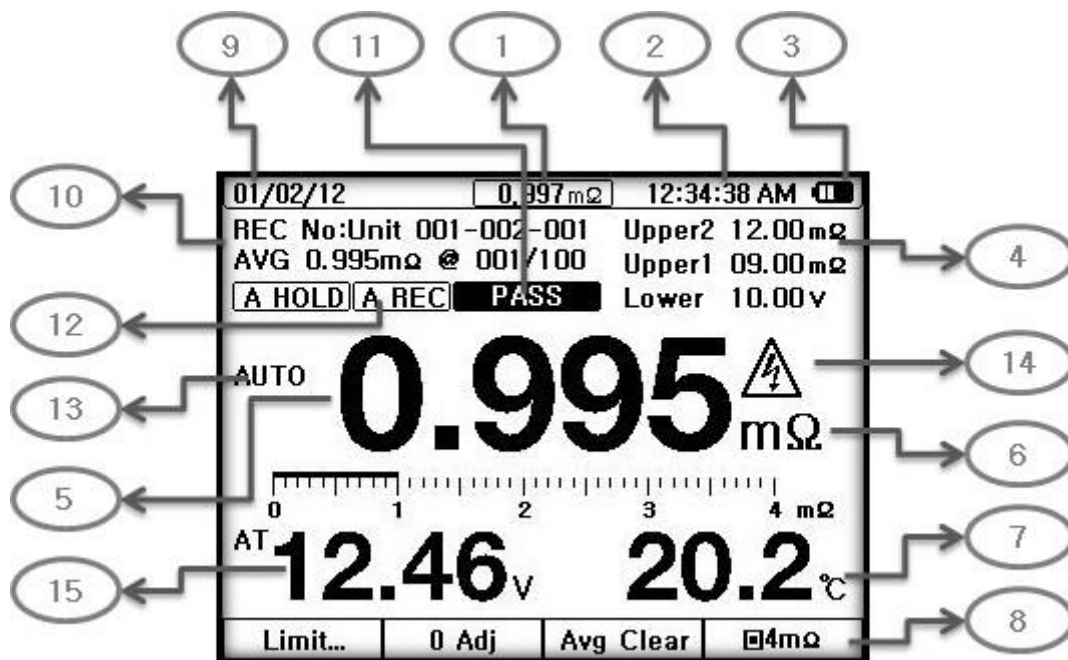

[Display]

- ① Present Measurement Value when AutoHold mode
 (When measurement at AutoHold mode, Auto Hold data “0.995” is holding at Center of Display and present measurement data shows “0.997”. This Data Box does not show if AutoHold mode stop)
- ② Measurement Data and Time
- ③ Battery/Adapter Sign
- ④ Limit: Upper, Lower
- ⑤ Impedance Value Display
- ⑥ Unit of Measurement
- ⑦ Temperature Value Display
- ⑧ 4m Ω Convert key
- ⑨ “ Unit-Cell-Times” display
- ⑩ Measurement Ave range and number of Averaged data
 (displayed with Auto Hold)
- ⑪ Limit (Comparator) Pass –Warning-Fail

- ⑫ Auto Saving : When Auto Holding, Auto Saving is automatically activated .
Saved at Auto Record Memory in order, max 300 cells x 100 times
measurement Record number : storage date Recording Number.
- ⑬ Auto : Auto, manual ranging
- ⑭ Warning Sign
- ⑮ DC Voltage measurement

1.5 Dimensions and Weight

Dimensions: 107 mm(W) x 220 mm(H) x 55 mm(D)/ 4.2" (W) x 8.3"(H)x2.2" (H)

Weight (main unit including battery) : 1.0 kg/ 2.2 lbs

2. Initial Setting before use

2.1 Battery Install and Replacement

Before start to use the Analyzer, install 2 x NiMH Battery Packs supplied with the Analyzer and charge up to full level if the charged level is not sufficient.

- Before install or replace Battery Pack, please Power Off of the Analyzer.
- After install or replace the Battery Pack, make sure to cover the Battery Pack with Battery Cover before use the Analyzer.
- Do not mix to use with other type of Battery.
Make sure to meet Correct Polarity Contact (+, -) of the Battery Pack to the Correct Polarity (+, -) of the battery room of the Analyzer.
Do not put reverse polarity. It also cause deterioration of capacity or Leakage
- Do not cut Battery Pack or draw into fire which is dangerous to cause explosion to wire.

- Dispose of the used battery according to regulation and rule.
- When Low Battery displayed in LCD screen, recharge it or replace it.

[Battery Replacement procedure]

- ① Power-Off the Analyzer. Disconnect Test Probes from the Analyzer.
- ② Open the Tilt Stand and unscrew the 2 x Battery Cover Screws on the Bottom Housing. Separate Tilt Stand and open the 2 Battery Cover (Left and Right).
- ③ Place 2 x NiMH Pack (3.6V) into Battery Room. Make sure to meet Correct Polarity Contact (+, -) of the Battery Pack to the Correct Polarity (+, -) of the battery room of the Analyzer.
- ④ Place Battery Covers and Tilt Stand
- ⑤ Fix the 2 x screws on the Battery Covers.

Recharging Adapter (Use for Recharging purpose only,
Not use for Measurement)

- Input Voltage: AC 100V~240V(Free Voltage)
- Output Voltage: DC 12V/1A 50/60 Hz

Battery Pack

- Voltage : 7.2V [NiMH 1.2V x3(3.6V) x 2 packs]
- Capacity: 2700 mA h

2.2 Insert Test Probe

To avoid measurement error or electrical shock, make sure to insert to the Analyzer correctly.

- For safe and accurate measurement of Resistance, Voltage , make sure to use the Battery Test Probe supplied with the Analyzer.
- Special care on any hurt from sharp tip of test probe during measurement.
Insert BNC type Test Probe to (+) and (-) as shown below picture.



[Insert Test Probe]

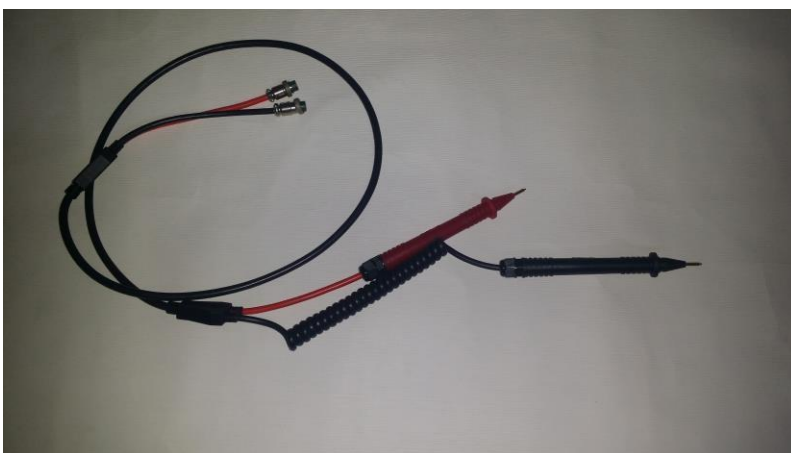

[Pin Type Battery Test Probe for Impedance, Voltage and Temperature measurement]

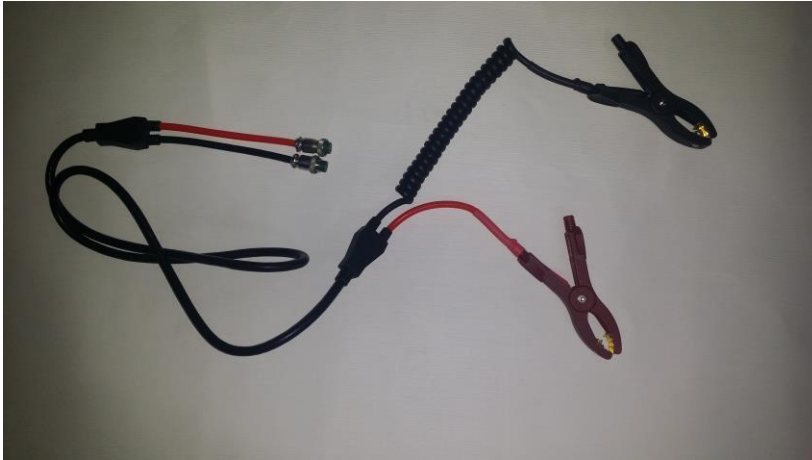

[Clip Type Battery Test Probe for Impedance, Voltage and Temperature measurement]) * Optional Accessory

- Current Probe (CT) * Optional Accessory
DC Current (DC 40A/400A ranges), SOC, Capacity measurements

2.3 Power ON/OFF

Use “POWER” key on the Analyzer to power ON or OFF.

Press longer than 2 seconds to power ON or OFF.

[ON]





- Press Power Key longer than 2 seconds. Then Power is “ON” with beeper sound.
- After Power “On”, Initial Display on Screen shows manufacturer and Firm Ware Information momentarily and change to Measurement function.
- Initial measurement function is always set Impedance (Internal Resistance) measurement.

[OFF]

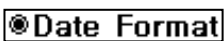

- Press Power Key longer than 2 seconds. Then Power is “OFF” with beeper sound.

2.4 Timer function

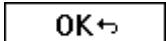
Once Power ON, timers works Real Time Clock. Upper Left area of LCD Screen display: Day / Month / Year, Hour / Minute / Second.

- Press “D/B User”  key for longer than 2 seconds to enter User mode. Select  “Year/Month/day” or “Day/Month/Year “
- If time is not correct, select  and  to adjust time.
- Set Day, Month, Year, Hour, Minute and press   key to complete Time setting.
- While setting Time, Timer is stop. Time may not accurate if takes long setting time.

2.5 Back Light Display

- Press  key , Back Light “ON” with click sound and
When backlight “OFF”, press  key .

3. Measurement(Resistance, Voltage-Current, Temp)

For Safe and Accurate measurement, read Manual carefully.

Make sure to pay attention on following

- Do not measure over DC 100 V Capacity Battery at Impedance Ω measurement range. Do not over DC 300V Input when measure Voltage at Capacity measurement range . This is to protect from Electric Shock
- Do not measure AC Voltage

[Caution]

- Do not Input exceeding Maximum Voltage, Currents of each measuring range. Exceeding Input may cause damage to the Analyzer.
- When measure Low Voltage Battery after measure High Voltage Battery, residue in Analyzer may damage Low Voltage Battery. Be sure to measure safely after discharge on DC Condenser inside of Analyzer by shorting the Test Probe.

[Note]

- Internal Resistance of Battery being measured can be different from Current Flow status and Discharge status. To support accuracy and reliability of judgment, be sure to measure at following condition.
- Lead Storage battery has big resistance on electrodes. Resistance can be different between the area of electrode toward Case and the area of End of Electrode. Contact area between Electrode and Test Probe should be consistent.
- Use USB type temperature probe to measure Temperature.
- Foreign materials or rust on electrodes may not measure or may cause measurement error. Need to clean electrodes before measurement.

3.1 Check Point before Measurement

- Check weather Test Probe is normal status.
 - ① Test Probe is recommended to “0” adjustment for accurate measurement.
Need to “O” adjustment with supplied Adjustment Board together with Analyzer and Test Probe.
 - ② Display should be “0000”. If “----” is displayed, Test Probe wire maybe broken or no contact.
- Check remaining battery capacity.
When use internal battery to operate, present battery status of the internal battery inside of Analyzer is displayed at Upper Right corner of LCD screen. When Low Battery is displayed, charge the battery through ADC Adapter / Internal Charger supplied with Analyzer or replace with new battery pack.
- Check the Battery Status to be measured.
- Any Foreign materials or rust on electrodes of the battery may not measure or may cause measurement error. Need to clean electrodes before measurement.

3.2 “0 ADJ “ O Adjustment Method and Procedure (Resistance measurement)

In order to get accurate measurement, When the Test Probe is replaced with new one or interval of Battery Terminal is not constant, strongly recommend to “O ADJ ” before measurement.

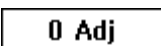
- Before measure Impedance, in order to improve accuracy, insert Test Probe to the “O” Adjustment Board (supplied with Unit) and proceed “0” Adjustment.
- Press   key for longer than 2 seconds on the Analyzer. Adjustment value to be set “0” and measurement value is displayed.
- If proceed “O ADJ” without Probe is inserted on “0 ADJ” board, “ Fail “ is displayed

- When conduct “0 ADJ”, “0” point of all ranges are automatically adjusted in order.
- Even though Analyzer power is Off, Adjusted Values are kept until next “0 ADJ”
- “0 ADJ” should be conducted with the “0 ADJ board” supplied with Analyzer.

□ How to short Test Probe when “0 ADJ ” is proceeding

1) Pin Type Test Probe

- Use “0 ADJ Board ” with AC 4-Terminal procedure
- As below illustration, select Hole meeting Distance between Battery Terminal(Electrodes) and press Probe Tip
- “0 ADJ Board ” is recommended as far as away from the Analyzer.

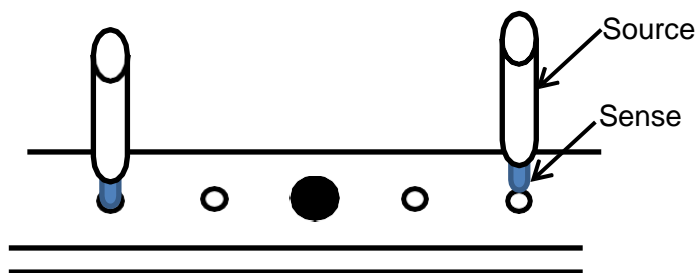

["0" ADJ]

- “0” Adjustment require to fit Tip of Probe down into the hole of “ O ADJ board “ and press down Probe so that SOURCE, SENSE terminal of Probe is stick together .
- Do not put “0 ADJ board” on Battery or Metal. Adjustment Error may occur from Electro Magnetic Interference.
- “O ADJ” can be done by Contact Pin - Pin of Probe or “ 0 ADJ Board. Other type of “0 ADJ” may cause Inaccurate Measurement.
- If the Battery Terminal – Terminal distance is longer than the Holes in the “ OADJ Kit ” , Use the 1st Left Hole and last Right hole in the Adjust Kit.

2) Clip Type Test Probe



[“ O ADJ]

- As shown above, Use Adjust Kit. Insert pin of Test Probe into the Adjust Kit to conduct “O Adjustment”

□ How to conduct “0 Adjustment”

① Insert Test Probe Pin to “ O Adjust Kit”

② Press **F2** | **0 Adj** key for longer than 2 seconds.

Test Probe to be connected to “0 ADJ”

- ☞ If Pin does not contact “O Adjust Kit “ within 10 seconds after **F2** | **0 Adj** key is pressed, “O Adj” can not proceed.
- ☞ When “0 Adj” value is out of range, Analyzer display Error Message and Adjust procedure stop.

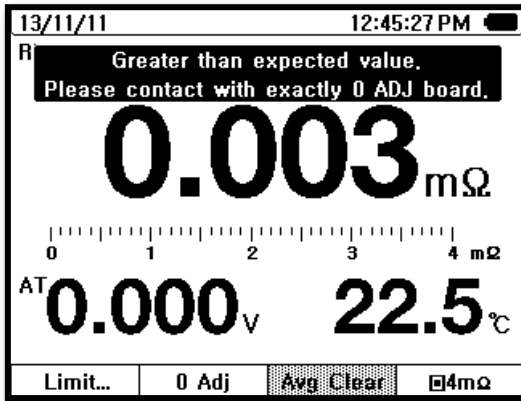

["0" ADJ processing display]

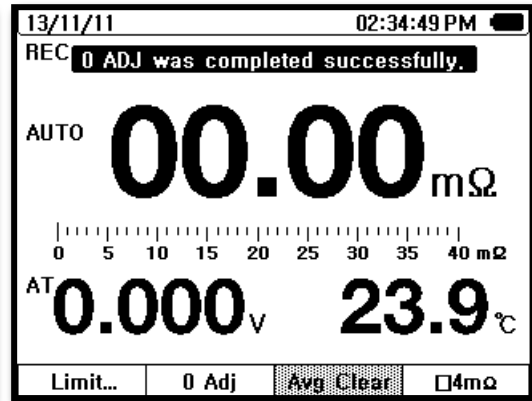

["0" ADJ complete display]

③ "0" Adjustment is conducted by Range in order.

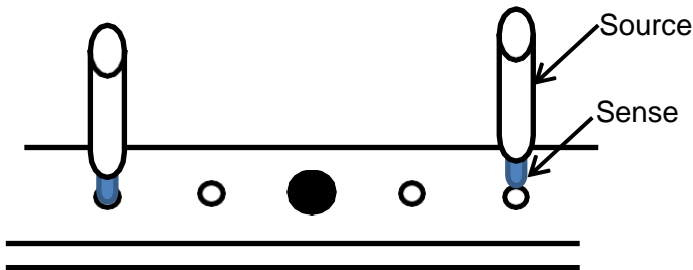

- Contact of Test Probe should remained until "0" ADJ is completed.

④ If Adjustment is completed, A confirmation message is displayed .

["0" Adjustment Error Display]

While "0" adjustment, Error will occur if Adjustment value is not achieved in normal condition or achieve over value above certain level

- Adjustment Value is achieved over 300 count.
- Test Probe is not connected to Analyzer.
- When there is foreign material on "0" ADJ board.
- Passed 10 seconds after "O ADJ" started.

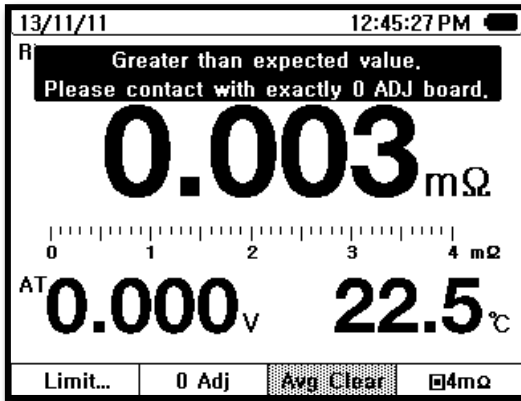

["0" ADJ Error Warning]

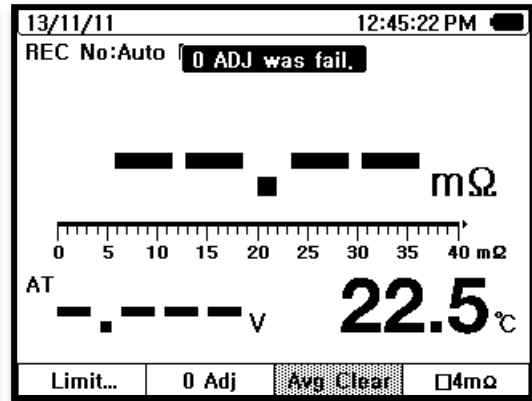

["0" ADJ Error Result]

3.3 Measurement (Resistance, Voltage-Current, Temp)

Resistance measurement operates Auto/Manual Ranging, Voltages operates Auto/Manual ranging and Current measurement in Manual Ranging.

AUTO means "Auto Ranging", Range means is "Manual Ranging".

Range key operation : when change AUTO ranging to Manual ranging, press key Short time. When change Manual ranging to Auto ranging, press key for longer than 2 seconds.

1) Resistance Ω

- If press Resistance " Ω " Ω key, Resistance, Voltage and Temperature are measured simultaneously.
- If press " Ω " Ω key, always enter Auto Ranging (40mΩ- 4 Ω)

4mΩ range is activated in Manual Ranging only – press **F4** **4mΩ** key to convert.

If need to change Range in Manual Ranging in 40mΩ- 4 Ω range, press Range Key **Range** and change Range with click sound. Each time key press changes Range respectively (moves decimal point each time).

- After change Range, when the Analyzer Power Off **Power** and Power On **Power** again, Measurement Range automatically revert ..

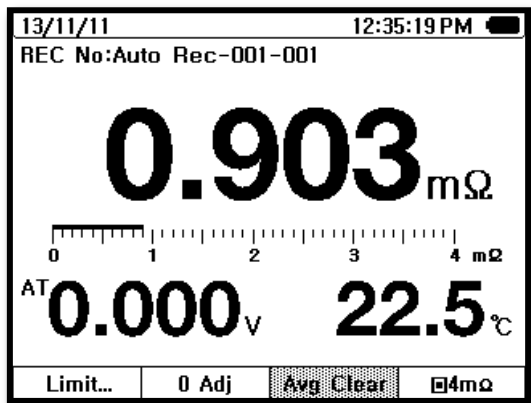



[Resistance measurement]

2) Voltage **Capacity**

- Note : Battery Voltage measurement (upto 100V) reading can be obtained automatically when Resistance **Ω** measurement mode. This mode **Capacity** uses when measure DC Voltage only upto 300V DC.
- If press **Capacity** key, Voltage, Current and Temperature are measured simultaneously.
- To enter Voltage Manual Ranging, press Range **Range** Key longer than 2 seconds then AUTO symbol on LCD screen is erased with click sound and set to

Manual Ranging (Range).

- If need to change Range in Manual Ranging, press Range  and change Range with click sound. Each time key press changes Range respectively (moves decimal point each time).
- When change from Manual Ranging to AUTO Ranging, press  Key longer than 2 seconds then AUTO symbol on LCD, Screen is displayed with click sound and set to AUTO Ranging.

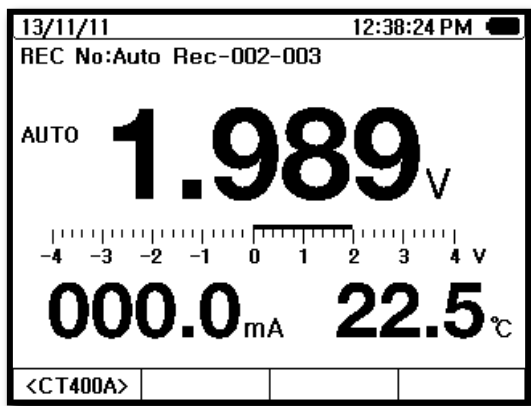

[Voltage measurement]

3) Current

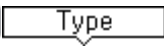

Current measurement is subsidiary measurement function in Voltage measurement function which always set in Manual Ranging

- If press   key, can
Select CT measurement : DC 40A or DC 400A . . After select it, Press Encoder (Center Rotator key) to complete setting.
Connect with external DC current probe (CT) and be sure the Select Range on Current Probe is set at 40A DC or 400A DC

How to connect Current Probe (CT) with the system and Analyzer

- Connect Current Probe (CT) as below illustration diagram. Insert the Input Jack of the CT to the lower part of the Analyzer (be sure Black lead goes to Black Input COM and Red(+) goes to Red Input Hole A) and Clamp the Jaw of the

Current Probe (CT) to the Cable between UPS (Loader/Charger) and Battery.

- If Battery Test Probe (connected between Unit and Battery Terminals) and Current Probe (CT) are connected together, Main Display (Voltage : V) and Sub display (Current - DC A and Temperature) are displayed simultaneously.

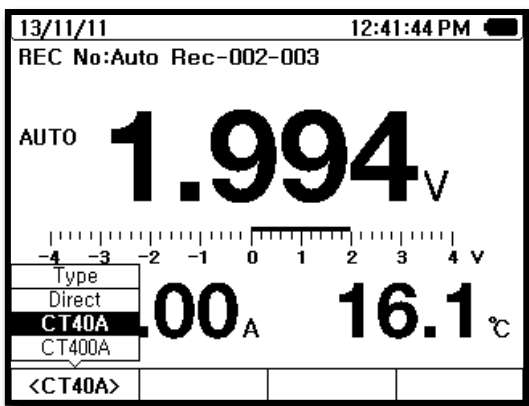

[Currents measurement]

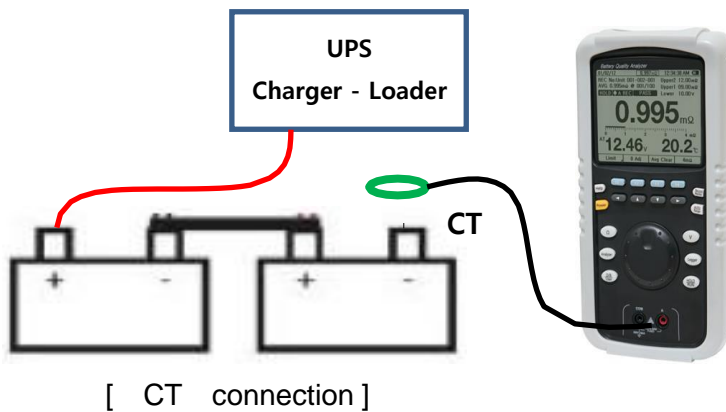

[CT connection]

NOTE

- Measurement through external Current Probe * Optional item
- The V.A function set at Voltage (V) at Main display
Currents (A) and Temp (deg) at Sub display.

4) Temperature

Temperature measurement is subsidiary measurement function in Resistance measurement Ω or Voltage measurement. While measuring Resistance or Voltage, Temperature measurement is displayed simultaneously.

Measured temperature indicates battery terminal temperature but not the internal battery temperature or electrolyte temperature

- °C or °F is selectable at User mode (press D/B User $\frac{D/B}{User}$ key for 2 seconds)

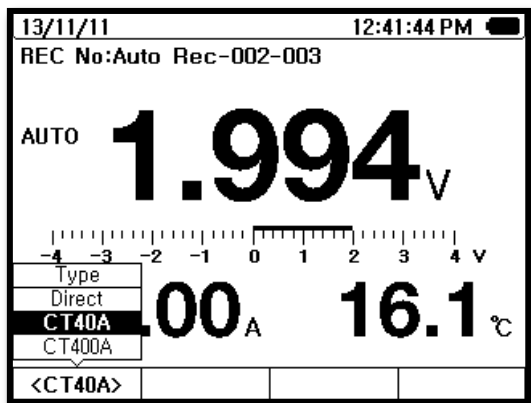

[Temperature measurement]

3.4 Auto Hold - Auto Record

1) Auto Hold (A_{HOLD})



- If pass 2 seconds after measurement, “Auto Hold” function is activated automatically to Auto Record of the measurement data.
- Press “HOLD/ AHOLD-AREC ”  key longer than 2 seconds to set “Auto Hold”
- If Auto Hold is set, **A HOLD** ” is displayed at top head middle line of LCD screen.
- When Measurement data shows “----”, Auto Hold does not activate
- Auto Hold and Auto Record always work together. If Auto Hold works, measured data automatically recorded at Auto Record memory room.
- When new measurement proceed while in Auto Hold, Auto Hold function is restarted.

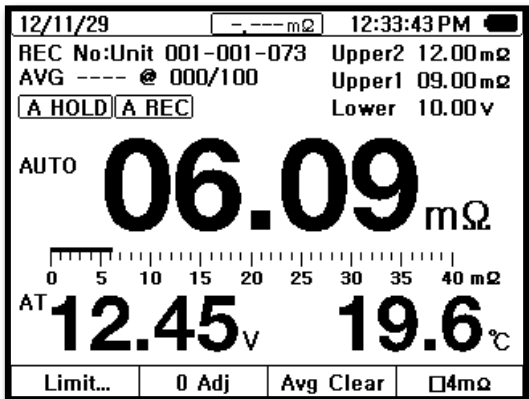

[Auto Hold]

2) Stop “Auto Hold” function

To stop “Auto Hold” function, press “HOLD/AHOLD-AREC”  key for longer than 2 seconds.

3) AVG Clear

- In “Auto Hold” function, AVG (Average) is automatically activated.

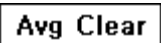
- AVG measurement function calculates average value from multiple repeated measurements (max 100 measurements) of the object battery in measurement deviation.
- AVG measurement is available only on Main Measurement.
- In Impedance (Internal Resistance) mode, Main measurement (main display) “Ω” can only be AVR measurement. Sub measurement (sub display) Voltage or Temperature can not be AVR measurement.
- In Voltage mode, Voltage can only be AVR measurement. Other sub display measurement can not be AVR measurement.
- To cancel “AVR” measurement, press   key. Then AVG is cleared and Initial Set up.

3.5 Data Hold

Present measurement Data can be holding if User wants to keep the data on LCD

display. To enter DATA HOLD mode, press HOLD  key one time for a short time. (if press longer than 2 seconds, may enter other mode : Auto Hold-Auto Record mode)

- To release from “Data HOLD”, press HOLD  key for a short time.

Impedance : Upper 1 level Max Limit (**WARNING**).

Upper 2 Level Max limit (**FAIL**).

Voltage : Minimum Limit (**WARNING**).

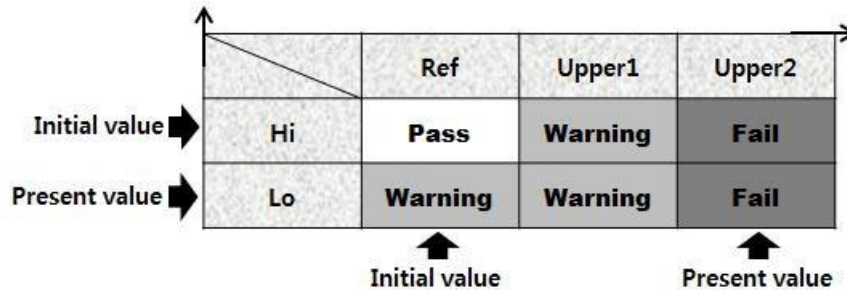

[LIMIT Setting]

- ◆ Press “Ω” Ω key (Impedance) and press **F1** **Limit...** key. Then, Limit Set Up display is appeared. Select **F1** **Limit** to activate. After LIMIT set up, measure battery and measurement result can be identified in one of Pass, Fail, warning.
- ◆ Limit set up can be done by User. Two kinds of Set Up method is available
 - ☞ Direct Setting Method.
 - ☞ Call from the data from D/B and setting.
- ◆ When there is measurement, main display shows 「---」 and Judgment result (Pass, Warning, Fail) does not display.
- ◆ When Power-Off the Analyzer, Already set Limit data is saved. When Power On and Limit “On”. The last set data is displayed.
- ◆ Voltage judgment is based on absolute value. Therefore measurement in Reverse polarity of Test Probe also to be valid. (saved as Absolute value)

4.2 Limit function Operation Procedure

1) Limit function selection

- ① In Impedance measurement mode (Ω), select **F1** | **Limit...**
- ② At Limit setting mode, set up Limit value at **F2** | **Recall...**
or **F3** | **Edit↓** and press **F1** | **Limit** to activate.
- ③ Press **F4** | **Back←** key or " Ω " **Ω** key to complete Limit setting.
- ④ After setting, Function is converted to measurement mode. upper right of Screen shows Limit value already set.
- ⑤ After measurement is completed, to release the function of LIMIT,
press **F1** | **Limit** and press **F4** | **Back↵**. Then Function is released and of LIMIT data at upper right of LCD screen is simultaneously disappeared.

2) Direct Input of LIMIT value

- ① At Limit setting mode, press **F3** | **Edit↓** Key.
- ② Press Direction Keys (Left/Up/Down/Right) and Encode Switch to set Limit value.
- ③ After Value is set, press **F1** | **Limit** to activate.
- ④ After Setting and Selection is done, **F4** | **Back↵** " Key to convert to Measurement stand by status.
- ⑤ At Measurement Stand by status. LIMIT values are displayed at Upper Right of LCD screen.

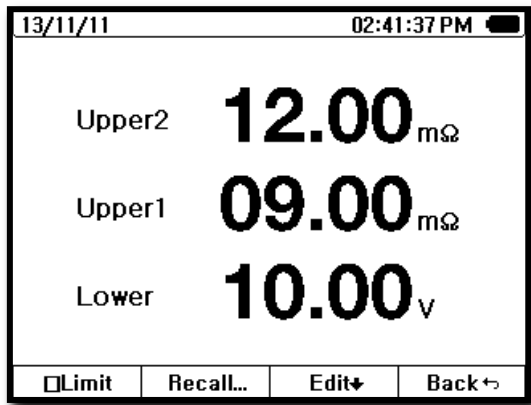





[LIMIT display]

3) Setting data calling from D/B (Recall)

Recall the DB in the Analyzer and use it as Limit Value set up.

If select the Value saved in D/B, it automatically set up. Desired D/B can be selected

by UP/Down   key or Encoder S/W .

- ① At Limit set up mode, press  "Recall" Key to move to D/B.
- ② Select desired D/B by using   key or Encoder Switch.
- ③ After D/B is selected, press  "Limit" to activate
- ④ Set Up or Selection is completed, press  "Back" key or Encoder Switch to enter Measurement Standby status.

4.3 Judgment of Limit

Limit set up Upper 1 level Max Limit, Upper 2 Level Max limit of Resistance and Minimum Limit of Voltage.

[Example]

Reference (Initial Set up)Value: Resistance value and Voltage value of New or Good battery (0.4Ω, 2V).

- ☞ Resistance Upper 1 Max Limit: 0.6Ω (1.5 times of Initial Value)
- ☞ Resistance Upper 2 Max Limit: 0.8Ω (2 times of Initial Value)

☞ Voltage Minimum Limit: 1.8V(90% of Initial Value)

[Set Up standard of Upper Max Limit and Lower Minimum Limit can be little different from Battery Type and Battery Manufacturer. Before set up, make sure this matter. Above is example of general standard]

[How to evaluate LIMIT – Comparator Table]

- ◆ Measured value of Resistance is lower than Upper 1 Level Max Limit, If Voltage measured simultaneously is higher than Minimum Limit “Pass”, If Voltage measured simultaneously is lower than Minimum Limit “Warning” light on.
- ◆ Measured value of Resistance is higher than Upper 1 Level Max Limit and lower than Upper 2 Level Max limit. If Voltage measured simultaneously is higher or lower than Minimum Limit, both case “Warning” light on with Beeper sound.
- ◆ Measured value of Resistance is higher than Upper 2 Level Max Limit. If Voltage measured simultaneously is higher or lower than Minimum Limit, both case “Warning” light on with Beeper sound.
- ◆ Any of Resistance or Voltages exceeds Limit, “Warning” or “Fail” message appear.

[If Judgment is “**PASS**”]

	Ref	Upper1	Upper2
Hi	Pass	Warning	Fail
Lo	Warning	Warning	Fail

Initial value
Present value

- ◆ Resistance is lower than Upper 1 Level Max Limit.
- ◆ Voltage is higher than Minimum Limit.

[If Judgment is “WARNING”]

		Ref	Upper1	Upper2
Initial value	Hi	Pass	Warning	Fail
Present value	Lo	Warning	Warning	Fail

↑ Initial value ↑ Present value

- ◆ Resistance is below than Upper 1 Level Max Limit. Voltage is below than Minimum Limit.
- ◆ Resistance is higher than Upper 1 Level Max Limit. Voltage is higher than Minimum Limit.
- ◆ Resistance is higher than Upper 1 Level Max Limit. Voltage is lower than Minimum Limit.

[Judgment is “FAIL”]

		Ref	Upper1	Upper2
Initial value	Hi	Pass	Warning	Fail
Present value	Lo	Warning	Warning	Fail

↑ Initial value ↑ Present value

- ◆ Resistance is higher than Upper 2 Level Max Limit. Voltage is higher than Minimum Limit.
- ◆ Resistance is higher than Upper 2 Level Max Limit. Voltage is lower than Minimum Limit.

[Comparator -LIMIT]

- ♦ Judgment of Battery Status indicates with Display and Beeper sound as per following table.

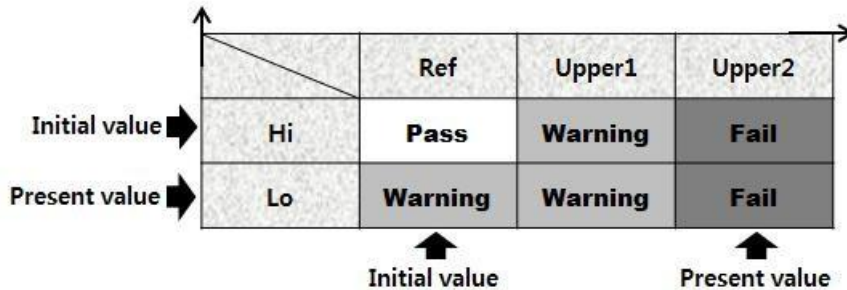

- ♦ Conditions
 - 1) Resistance: $PASS \leq \text{Upper 1 Level MAX limit} \leq \text{WARNING} \leq \text{Upper 2 Level Max Limit} < \text{FAIL}$
 - 2) Voltage: $\text{WARNING} < \text{Minimum Limit} < \text{PASS}$

4.4 LIMIT function – Beeper Set Up

When judge the measured value with comparator, Beeper sounds depend on result of judgment. User can recognize the Result from different Beeper sound.

Judge Result	Beeper Sound
PASS	After judgment, sounds 1 time for short time(100ms).
WARNING	After judgment, sounds 2 times shortly(each 150ms).
FAIL	After judgment, sounds 1 time for long.(400ms)

4.5 Release LIMIT function

To release LIMIT function, in LIMIT set up mode, select F1 “Limit” to stop the Limit mode.

5. Record



5.1 Record function

Save the measured data to Internal Memory or recall the saved data. Press

RECORD key.

Saved Data includes “**Date, Hour, Resistance Value, Voltage Value, Temperature, Comparator Limit value, Judgment Result**”.

Saved Data can be recalled and display form in Trend Graph which is very useful for Deterioration Trend Analysis.

Saved Data can transmit to Computer for Storage in Computer memory.

5.2 Record Diagram

Memory Format is consists of 251 unit (bank).

There are max 251 Unit (including 1 Open Unit No : 000 - Reference D/B not registered and Registered Unit No: 001 ~ 250 : Reference D/B registered)
1 unit has max 300 cells. 1 cell (battery) has 100 slot (measurement times)

Therefore, 1Unit (bank) - Length 300 cells x Width 100 Slot per cell

1 unit contains 30,000 data. Analyzer inside Memory can save total 251 Units which total 7,530,000 measurement data.

Unit	Cell	Address						
Open Unit	Cell001	001	002	003	..	098	099	100
	..	001	002	003	..	098	099	100
Unit 001	Cell300	001	002	003	..	098	099	100
	Cell001	001	002	003	..	098	099	100
	..	001	002	003	..	098	099	100
..	Cell300	001	002	003	..	098	099	100
	..	001	002	003	..	098	099	100
	..	001	002	003	..	098	099	100
Unit 250	Cell001	001	002	003	..	098	099	100
	Cell300	001	002	003	..	098	099	100

1)Unit (Bank)

Total Battery Bank is consist of many battery which is connect to 1 UPS .

Batteries consisting Unit should be same Battery Model.

Each Unit takes a Reference Data which is selected from Impedance D/B.

When the measuring Unit Reference D.B is not registered , the Unit measurement is recorded at Open Unit No. 000. Open Unit may have Limited Analyzer function including Trend Graph , Report Output through PC .etc.

Meter mode (Voltage, Current, Temp)measured **V·A** key function can be recorded at Open Unit only, while other Registered Units (No :001 ~ 250) can not record meter mode because the 001 ~ 250 Unit Reference D/B are already registered.

Addition , Correction and Delete of Unit can be done through PC Software

2)Cell (Battery)

Each Battery consist of Unit is called Cell .

Measure Each Cell maximum 100 times in order and record on each slot.

Record for references of Battery Deterioration Analysis.

Measure Cells while “ A REC” is on . Cell number is increased by one by one and saved in order.

5.3 Record Display

Press Encoder Switch to call the Unit Index List .

Use up/down/left/right direction keys on the Analyzer to select the Record Address.

List on the Display is RECORD SPACE of selected unit.

Wide is Slot number (001 ~100) of each cell , Long is Cell number (001~300).
Data Recorded space indicates Judgment Result (P : Pass W : Warning F : Fail)
When select Unit, Reference Data of Unit shows at bottom.

Move Cursor to select the Recorded Address. then ,Recorded Data displayed at bottom .







13/11/11		02:42:21 PM							
001 Unit 1									
	065	066	067	068	069	070	071	072	073
Cell 001	P	P	P	P	P	P	P	P	
Cell 002	P	P	P	P	W	W	W	W	
Cell 003	P	W	W	W	W	W	W	W	
Cell 004	W	W	W	W	F	F	F	F	
Cell 005	P	P	P	P	W	W	W	W	
Cell 006	P	P	P	W	P	W	W	W	
Cell 007	W	W	W	W	W	W	W	W	
Cell 008	W	W	W	W	W	W	W	F	
Roket RP100-1 Lead-acid 100,0AH									
12,00V (10,00V) 06,00mΩ (09,00mΩ/12,00mΩ)									
08.41mΩ 12.01V 019.6°C 14/01/18 10:12:56 PM									
Start	Replay...	Manage	Exit						

5.4 Unit Set Up

Unit is the Group of batteries to be measured.

However Open Unit (# 000) does not have registered D/B which limits Analysis function. To use Analysis function, need to set up unit and D/B of the battery.

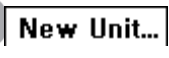
[Unit Addition on Unit]

- ① Press "Record"  key to enter RECORD display screen.
- ② Press Encoder key (Big Round key at Center of Unit) to display UNIT LIST
- ③ Use Up/Down   key to move to Vacant Unit number
- ④ Press   key to convert to New Unit Page Display Screen
- ⑤ Use   keys to select Reference data from D/B . And press

F3 **OK** key to finish New Unit set up

- ⑥ Modification of Model Number , Manufacturer name need to be done through PC Software.
- ⑦ New Unit is displayed on Unit List .

Unit Add ,Edit can be done through PC software

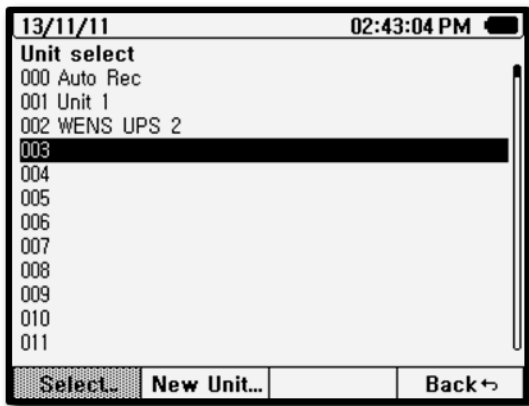



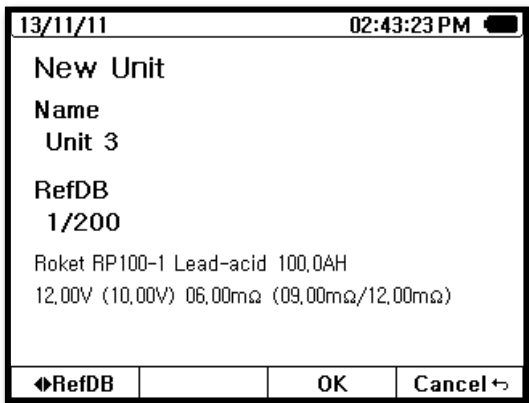



[New Unit Number selection]



[New Unit Display]

5.5 Address set up

[Address set up Procedure]

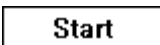
- ① Press “Record”  key to enter setting menu.
- ② Select Unit and Address by Left/Right/Up/Down     direction keys or Encoder Switch.
- ③ After selection of Unit and Address, press Encoder Switch or F1   to complete setting and convert to record standby mode.
- ④ When operating at “ A-REC” mode, automatically recorded at next address.

[NOTE]

When start Recording, please follow above procedure.

- ◆ If the address is already used or in use, it tells the status and ask whether to use next address or overwrite on already existing data in the address.
- ◆ If record without address, record at temporary room which is A-Record in order.
- ◆ When convert to measurement mode from record stand-by mode, selected unit and address are shown on LCD screen.
- ◆ If impedance value shows [----], can not record.

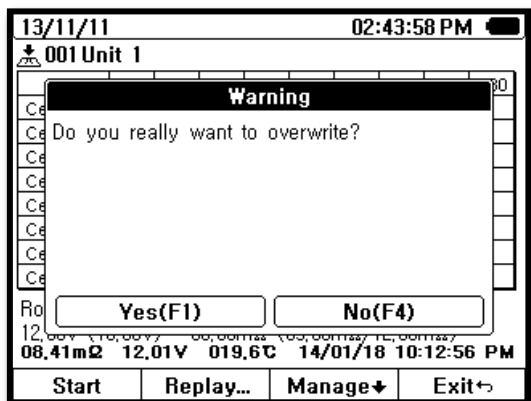



[Overwrite Saving]

5.6 A-REC (Auto Recording)



- ◆ “Auto Recording” function can transfer the measured data and automatically store in series simultaneously when measure the data.

[Operation Method and Procedure]

1) Auto Recording Operation Method

- ◆ Before start , select Record Address of the battery (please refer 5.5 Record Address set up)
- ◆ Press “ AHOLD-AREC ”  key for longer than 2 seconds to display  symbol at upper LCD screen.
- ◆ When start measurement with Analyzer, once Auto Hold activates the measured data recorded at memory and recorded address is displayed.
- ◆ Recorded Data is stored in sequence of input. When filled up the record memory space 100 slots , first come first out base, stored data will be removed from 1st stored data and 2nd stored data as # 101 data and # 102 data come in storage room in memory.









2) Management of A-Record data.

- ◆ Unless Record Mode is not released, measured data is continuously recorded.
- ◆ To release A-Record mode, press “Record”  key longer than 2 seconds. “REC NO” on LCD screen will also be disappeared simultaneously.
- ◆ Recorded data at A-Record can move to desired Unit, Address by Up/Down/Left/Right  direction key and encoder switch.,
- ◆ When select address by Left  direction key or Encoder Switch, information (measured date, time, item) of measured data displayed on LCD screen.

5.7 Replay of Recorded Data

Recall the Recorded data from memory and replay the data.

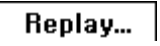
[Operation Procedure]

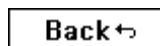
- ① Press "Record"  Key for longer than 2 seconds to enter Initial Display of Record/Replay.
- ② Select the Replay Data from Recorded Data Address by Left/Right/Up/Down     direction key or Encoder Key. After select, press F2   key to show recorded data on display.
- ③ When in Replay, Record Data with REC No is displayed on LCD screen.
- ④ To continue to Replay of other Recorded Data, press   while in replaying the data. Then, Initial Display appears and may proceed as above step 2.
- ⑤ When convert to measurement mode, press any measurement key on Analyzer.

[NOTE]

- ◆ If select Record Address, Record Data and Recorded Data are displayed at bottom of display.
- ◆ Limit judgment result also displayed together (If Reference (Initial) data of the Unit is set)
- ◆ If there is no Recorded Data, displayed in Blank.

[Replay LCD screen]

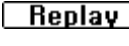
- ◆ Recorded Date will replay in LCD Screen – STILL status.
- ◆ Upper Center of Screen shows  "Replay".
- ◆ REC No of Replay Data shows at Upper Left of Screen.

13/11/11 02:42:21 PM

001 Unit 1

	065	066	067	068	069	070	071	072	073
Cell 001	P	P	P	P	P	P	P	P	
Cell 002	P	P	P	P	W	W	W	W	
Cell 003	P	W	W	W	W	W	W	W	
Cell 004	W	W	W	W	F	F	F	F	
Cell 005	P	P	P	P	W	W	W	W	
Cell 006	P	P	P	W	P	W	W	W	
Cell 007	W	W	W	W	W	W	W	W	
Cell 008	W	W	W	W	W	W	W	F	

Roket RP100-1 Lead-acid 100,0AH
 12,00V (10,00V) 06,00mΩ (09,00mΩ/12,00mΩ)
08,41mΩ 12,01V 019,6°C 14/01/18 10:12:56 PM

Start Replay... Manage↕ Exit↵

[Replay Select]

13/11/11 Replay 02:44:44 PM

REC No:Unit 001-001-072 Upper2 12.00mΩ
 Unit 1 Upper1 09.00mΩ
PASS Lower 10.00v

08.41 mΩ

0 5 10 15 20 25 30 35 40 mΩ

AT **12.01** v **19.6** °C

Back↵

[Replay Screen]

5.8 Erase of Recorded Data

[Operation Procedure]

- ① Press Record key to enter initial screen of Record
- ② Select F3 Manage↕ key
- ③ Select the Data to erase from Recorded Data Address by Left/Right/Up/Down ← → ▲ ▼ direction key
- ④ After Address is selected, press F3 Erase key to erase of the data.
- ⑤ If press F3 Erase key To erase single data, press the key for a short time. To erase whole Unit record, press the key for longer than 2 seconds. Then A Pop Up widow will open and after Confirmation, whole Unit record can be erased.
- ⑥ Press F4 Back↵ to exit from the Erase function

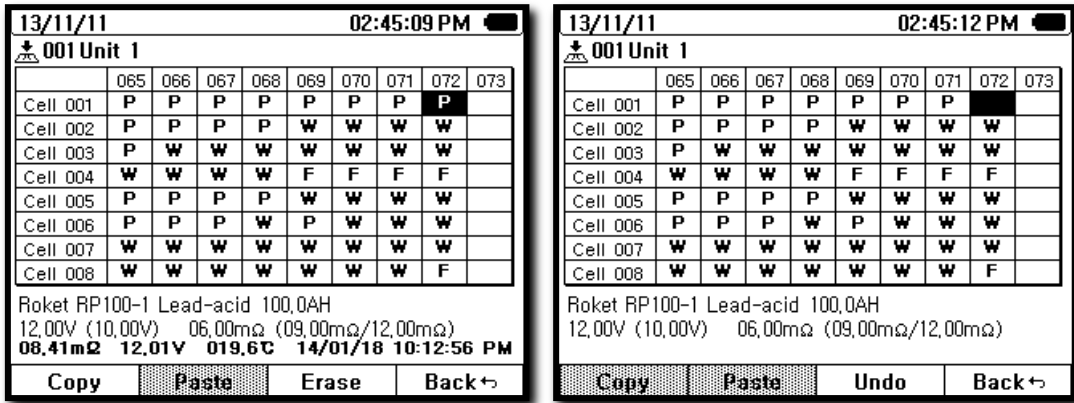

[Erase Data]

5.9 How to input Reference (Initial) Data

Each Battery Cell (unit) Reference Data can be little bit different each other under Battery Management System. Need to achieve the Battery Cell (unit) Reference data (initial data) and input it to Data Base (D/B) in the Analyzer in advance. The Measurement Data (measurement periodically) after use the Battery will be recorded and accumulated in the Memory of the Analyzer to create Battery Trend Curve compare with the reference (initial) data and provide information of Battery Deterioration judgment (Battery Health)

After Record/Replay is selected, use left/right/up/down direction keys or Encoder to select unit ,then, recorded DB data is displayed at bottom of display.

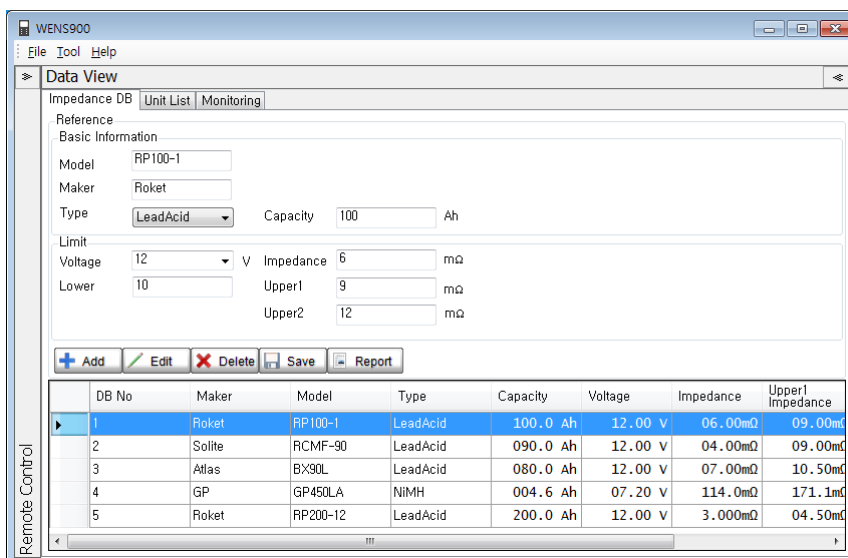

[Input Reference Input Display]

1) How to input from PC program

[Operation Procedure]

- ① Activate Analyzer after connecting PC Interface Software program.
- ② Activate “Impedance DB” on PC program. .
- ③ Input reference data of New battery .
- ④ Press “ADD” key to store .

2) Unit information Input procedure

Input Location of Unit and Basic Information of Battery which support more efficient battery management. Use Impedance DB previously input as basic data information

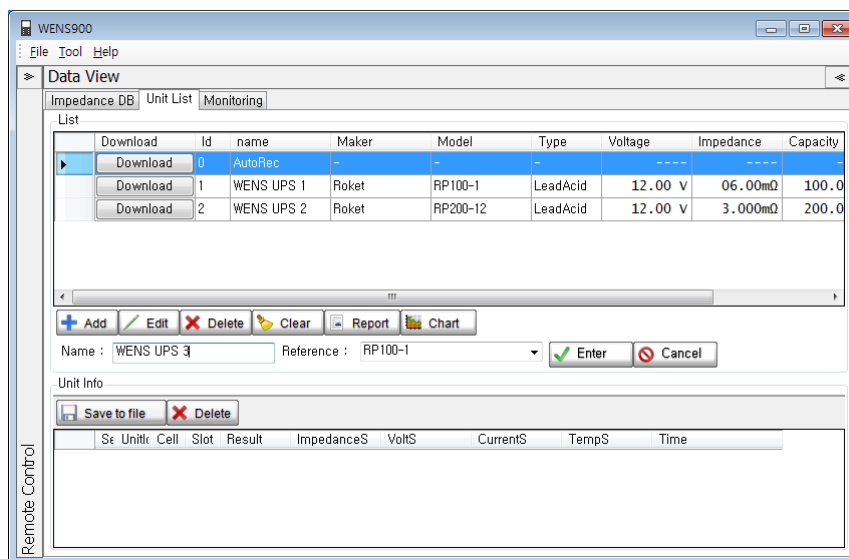







[Unit Information Input]

[Input through PC Software]

- ① Click “Unit List” on PC Program window.
- ② Select Unit to input or correct Data .
- ③ Press ADD or Edit.
- ④ Input Location Information and select DB value in Reference.
- ⑤ After complete Input, press “ENTER” at right side of PC program .
- ⑥ Input Value is confirmed directly on display of Analyzer

[Input through Unit Program]









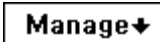

- ① At RECORD display, press Encoder key to display “Unit List”
- ② Move to vacant address through   key.
- ③  **New Unit** Key to enter NEW UNIT Display
- ④ Press  Reference D/B key and select Reference D/B by 
 key or Encoder key.
- ⑤  **OK** key to complete.

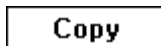
Modification of Unit Name is available only through PC Program.

5.10 Move of Recorded Data

Move any specific measurement data stored in Auto Record to specific Unit for Management.

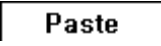
[Moving Procedure]

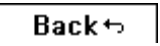
- ① At Initial mode of Record function, press   key..
- ② Select Data of Address to be moved by left/right/up/down direction key or Encoder
- ③ Press   key to select data. . .
- ④ Select Final Address to be moved by Left/Right / Up/Down  
  keys or Encoder key.
- ⑤ Select   to move Data..
- ⑥ Press   key to return to previous display or press any major function key to measurement mode..

13/11/11 02:47:20 PM

001 Unit 1 Record was copied.

	065	066	067	068	069	070	071	072	073
Cell 001	P	P	P	P	P	P	P	P	P
Cell 002	P	P	P	P	W	W	W	W	
Cell 003	P	W	W	W	W	W	W	W	
Cell 004	W	W	W	W	F	F	F	F	
Cell 005	P	P	P	P	W	W	W	W	
Cell 006	P	P	P	W	P	W	W	W	
Cell 007	W	W	W	W	W	W	W	W	
Cell 008	W	W	W	W	W	W	W	F	

Roket RP100-1 Lead-acid 100,0AH
 12,00V (10,00V) 06,00mΩ (09,00mΩ/12,00mΩ)
 08,41mΩ 12,01V 019,6°C 14/01/18 10:12:56 PM

Copy Paste Erase Back↵

[Record Data Copy]

13/11/11 02:46:35 PM

001 Unit 1 Record was pasted.

	065	066	067	068	069	070	071	072	073
Cell 001	P	P	P	P	P	P	P	P	P
Cell 002	P	P	P	P	W	W	W	W	
Cell 003	P	W	W	W	W	W	W	W	
Cell 004	W	W	W	W	F	F	F	F	
Cell 005	P	P	P	P	W	W	W	W	
Cell 006	P	P	P	W	P	W	W	W	
Cell 007	W	W	W	W	W	W	W	W	
Cell 008	W	W	W	W	W	W	W	F	

Roket RP100-1 Lead-acid 100,0AH
 12,00V (10,00V) 06,00mΩ (09,00mΩ/12,00mΩ)
 08,41mΩ 12,01V 019,6°C 14/01/18 10:12:56 PM

Copy Paste Erase Back↵

[Data Paste]

6. Analyzer Analyzer

Analyzer function is very specialized and independent function.

Measured Data and Saved Values enable to judge the Battery Health in management precisely and enable to analyze Deterioration Trend and decide Time of replacement.

6.1 Recall

[Operation Procedure]

Press "Analyzer" Analyzer key for a short time to enter Analyzer function.

① When UNIT LIST is displayed on display, select Desired Unit to analyze

by Up/Down ▲ ▼ keys and press F1 Select.. key

② Press F1 Select.. key to select Data Type (Cell or Slot)

If want to see Deterioration Analysis on specific individual battery,select "Cell".

If press F2 Data Table, recoded data is displayed in Table format

If press F3 Trace, Trend Curve of Battery Deterioration is displayed.

13/11/11		05:35:12 PM							
001 Unit 1									
	065	066	067	068	069	070	071	072	073
Cell 001	P	P	P	P	P	P	P	P	
Cell 002	P	P	P	P	W	W	W	W	
Cell 003	P	W	W	W	W	W	W	W	
Cell 004	W	W	W	W	F	F	F	F	
Cell 005	P	P	P	P	W	W	W	W	
Cell 006	P	P	P	W	P	W	W	W	
Cell 007	W	W	W	W	W	W	W	W	
Cell 008	W	W	W	W	W	W	W	F	
Recall Type	Lead-acid 100,0AH								
Cell) 06,00mΩ (09,00mΩ/12,00mΩ)								
Slot									
<Cell>	DataTable	Trace	Exit↵						

[Analysis Selection : Cell]

If want to see measurement records done on many batteries at specific measurement time, select “ Slot

13/11/11		05:35:21 PM							
001 Unit 1									
	065	066	067	068	069	070	071	072	073
Cell 001	P	P	P	P	P	P	P	P	
Cell 002	P	P	P	P	W	W	W	W	
Cell 003	P	W	W	W	W	W	W	W	
Cell 004	W	W	W	W	F	F	F	F	
Cell 005	P	P	P	P	W	W	W	W	
Cell 006	P	P	P	W	P	W	W	W	
Cell 007	W	W	W	W	W	W	W	W	
Cell 008	W	W	W	W	W	W	W	F	
Recall Type	Lead-acid 100,0AH								
Cell) 06,00mΩ (09,00mΩ/12,00mΩ)								
Slot	01V 019,6°C 14/01/18 10:12:56 PM								
<Slot>	DataTable	Trace	Exit↵						

[Analysis selection : Slot]

6.2 Data Table

The function shows Recorded Measured Data in Data Table

□ When select “ Cell “

Data is displayed in the reversed order of Slot number.

Can analyze measurement vale change on specific battery (cell) by Measurement time base.

□ **When select "Slot"**

One measurement time(Slot), Impedance of many batteries are measured.

If Batteries of unit installed at same time, date, Impedance of the batteries increase similar. If any Specific Cell shows higher impedance data than average data, the specific cell deteriorates in quickly than the others.

Useful function to quick detect and manage such risky battery









Battery Deterioration Order Sort Table

Sort by order of Impedance data, Voltage order or Measurement (Slot) time which is very useful to check and manage

1) Cell

Accumulated measurement data of individual cell can be sorted by order from highend Impedance slot to lower impedance slot, from lower voltage slot to higher voltage slot or from latest measurement slot to older time slot.

[Operation Procedure]

- ① Press  key to enter the Analyze
- ② When Unit List is on window, select "Unit"
- ③ press   key to select Unit to analyze and press  "**select**" key.
- ④  "**call**" key to decide Data to call.
- ⑤ select " Cell "
- ⑥ press  "**Data Table**"
- ⑦ press 
- ⑧ press  < # > . Then, a pop up window showing # (slot number), **Ohm, V** is on, then select .

13/11/11 03:01:33 PM

Record No Unit : 001 Cell : 002

Unit info
Unit 1
Roket RP100-1 Lead-acid 100,0AH
12,00V (10,00V) 06,00mΩ (09,00mΩ/12,00mΩ)

There are 72 records.

#▼	Ω	Ω%	V	V%	℃	Time
072 W	09,55mΩ	-0,0	12,19v	-0,0	19,7℃	14/01/18
071 W	09,25mΩ	-0,0	12,12v	-0,0	20,4℃	14/01/04
070 W	09,43mΩ	-0,0	12,24v	-0,0	19,6℃	13/12/21
069 W	09,24mΩ	-0,0	12,14v	-0,0	19,6℃	13/12/07
068 P	08,96mΩ	-0,0	11,94v	-0,0	19,5℃	13/11/23
067 P	08,87mΩ	-0,0	11,91v	-0,0	19,5℃	13/11/09

Unit info <#> Back←

[Data Table display]

13/11/11 03:01:33 PM

Record No Unit : 001 Cell : 002

Unit info
Unit 1
Roket RP100-1 Lead-acid 100,0AH
12,00V (10,00V) 06,00mΩ (09,00mΩ/12,00mΩ)

There are 72 records.

#▼	Ω	Ω%	V	V%	℃	Time
072 W	09,55mΩ	-0,0	12,19v	-0,0	19,7℃	14/01/18
071 W	09,25mΩ	-0,0	12,12v	-0,0	20,4℃	14/01/04
070 W	09,43mΩ	-0,0	12,24v	-0,0	19,6℃	13/12/21
069 W	09,24mΩ	-0,0	12,14v	-0,0	19,6℃	13/12/07
068 P	08,96mΩ	-0,0	11,94v	-0,0	19,5℃	13/11/23
067 P	08,87mΩ	-0,0	11,91v	-0,0	19,5℃	13/11/09

Unit info <#> Back←

[Data Table display option]

13/11/11 03:01:38 PM

Record No Unit : 001 Cell : 002

There are 72 records.

#▼	Ω	Ω%	V	V%	℃	Time
072 W	09,55mΩ	-0,0	12,19v	-0,0	19,7℃	14/01/18
071 W	09,25mΩ	-0,0	12,12v	-0,0	20,4℃	14/01/04
070 W	09,43mΩ	-0,0	12,24v	-0,0	19,6℃	13/12/21
069 W	09,24mΩ	-0,0	12,14v	-0,0	19,6℃	13/12/07
068 P	08,96mΩ	-0,0	11,94v	-0,0	19,5℃	13/11/23
067 P	08,87mΩ	-0,0	11,91v	-0,0	19,5℃	13/11/09
066 P	08,18mΩ	-0,0	12,14v	-0,0	19,7℃	13/10/26
065 P	08,05mΩ	-0,0	11,95v	-0,0	20,4℃	13/10/12
064 P	07,89mΩ	-0,0	11,95v	-0,0	19,9℃	13/09/28
063 P	08,02mΩ	-0,0	11,92v	-0,0	20,2℃	13/09/14

Unit info <#> Back←

[Data Table Unit Information Hide]

13/11/11 03:26:58 PM

Record No Unit : 001 Cell : 002

Unit info
Unit 1
Roket RP100-1 Lead-acid 100,0AH
12,00V (10,00V) 06,00mΩ (09,00mΩ/12,00mΩ)

There are 72 records.

#▼	Ω	Ω%	V	V%	℃	Time
072 W	09,55mΩ	-0,0	12,19v	-0,0	19,7℃	14/01/18
071 W	09,25mΩ	-0,0	12,12v	-0,0	20,4℃	14/01/04
070 W	09,43mΩ	-0,0	12,24v	-0,0	19,6℃	13/12/21
069 W	09,24mΩ	-0,0	12,14v	-0,0	19,6℃	13/12/07
068 P	08,96mΩ	-0,0	11,94v	-0,0	19,5℃	13/11/23
067 P	08,87mΩ	-0,0	11,91v	-0,0	19,5℃	13/11/09

Sort 4v -0,0 19,6℃ 13/12/21
4v -0,0 19,6℃ 13/12/07
Impedance 4v -0,0 19,5℃ 13/11/23
Volt 1v -0,0 19,5℃ 13/11/09





Unit info <#> Back←

[Data Table Display Order Selection]

2) Slot

Accumulated measurement data of The multiple cells in the unit are measured same slot (measurement time). The cells can be sorted by order from highend Impedance cell to lower impedance cell, from lower voltage cell to higher voltage cell or from latest measurement cell to older time cell

[Operation Procedure]

- ① Press  key to enter the Analyze
- ② When Unit List is on window, select "Unit"
- ③ press   key to select Unit to analyze and press  "select" key.
- ④ press  "call" key to decide Data to call.

- ⑤ select " Slot "
- ⑥ press **F2** "Data Table"
- ⑦ Press **F1**
- ⑧ press **F2** < # > . Then, a pop up window showing # (cell number), Ohm,
- ⑨ V is on, then select one of them.

#	Ω	$\Omega\%$	V	V%	$^{\circ}\text{C}$	Time
005	10.49m Ω	-0.0	11.83V	-0.0	19.8 $^{\circ}\text{C}$	23:32:07
061	10.44m Ω	-0.0	12.27V	-0.0	19.8 $^{\circ}\text{C}$	23:33:28
069	10.27m Ω	-0.0	12.28V	-0.0	19.9 $^{\circ}\text{C}$	23:33:40
011	10.19m Ω	-0.0	12.26V	-0.0	20.3 $^{\circ}\text{C}$	23:32:15
082	09.94m Ω	-0.0	11.98V	-0.0	19.6 $^{\circ}\text{C}$	23:33:59
030	09.84m Ω	-0.0	11.97V	-0.0	19.7 $^{\circ}\text{C}$	23:32:43

[Deterioration Order Table : Resistance]

6.3 Trace (Trend Curve Analysis) and Fitting (Battery Change Estimation)Trace (Trend Curve Analysis)

- ◆ Impedance, Voltage measurement data saved at RECORD -memory (in Unit/Cell address) are displayed in Curve Line which allows to observe the Trend of the change.

Impedance, Voltage, Temperature line thickness are displayed differently for user Recognition convenience.

[Operation Procedure]

- ① Press **Analyzer** key.

- ② Press **F1** **Select..** UNIT-Cell
- ③ Press **F3** **Trace** to enter TRACE mode
- ④ Select Soft Key Menu **F1** **Zoom** **F2** **◀<Cursor>** **F3** **□Fitting** as needed.
- ⑤ To exit from TRACE mode to previous mode , press **F4** **F4** Exit key .
To exit from ANAYZER function, press Analyzer key for a short time.

[Note]

Measurement Number of dots (displayed in Line) is maximum 100 per cell.

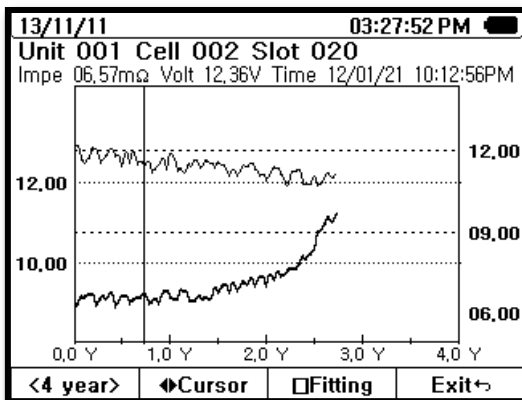

[TRACE Display]

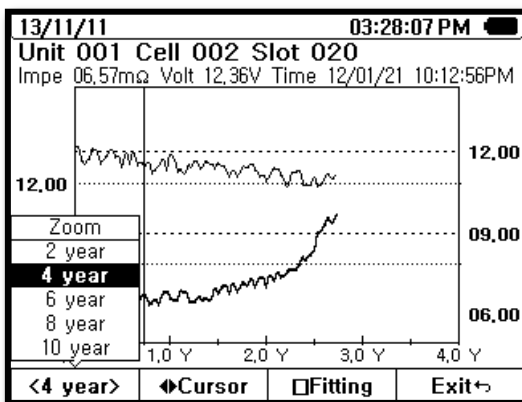

[TRACE Zoom : X Axis 4 year]

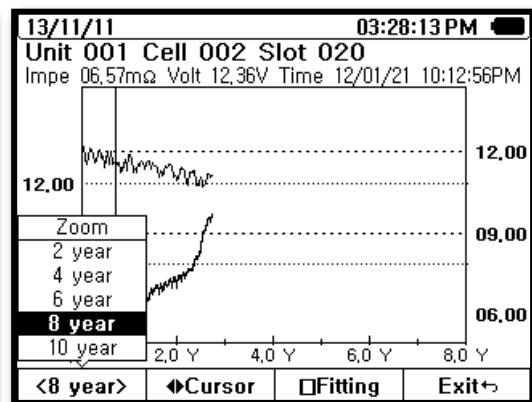

[TRACE Zoom : X Axis 8 year]

X Axis indicates TIME. Y Axis curve changes according to Impedance, Voltage measurement data.

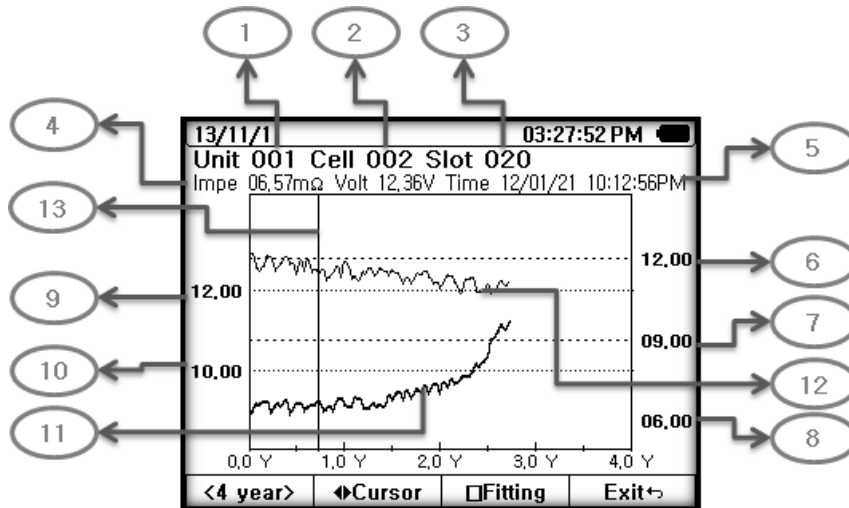

- ① Unit (Bank) number.
- ② Battery Cell number.
- ③ Slot(Measurement) number of Cell 002.
- ④ Measurement Data (Impedance, Voltage) of Slot 20.
- ⑤ Measurement Time of Slot 20.
- ⑥ Upper 2 (FAIL)Impedance level of Cell. 002 (Reference Impedance x 2.0 times)
- ⑦ Upper1 (Warning) Impedance level of Cell. 002 (Reference Impedance x 1.5 times)
- ⑧ Reference Impedance of Cell. 002
- ⑨ Reference Voltage of Cell.002
- ⑩ Lower Voltage level of Cell.002 (90 % level of Reference Voltage)
- ⑪ Impedance Trend Curve of Cell.002 based on saved measured data of Slot
- ⑫ Voltage Trend Curve of Cell.002 based on Saved measured data.



⑬ Vertical Bar (Cursor) to move left –right of Slot (measurement)



[How to select the Slot – measurement number]

Vertical Bar can pick up the Slot no- measured data and

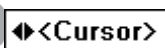
Shows on upper top area of display. To see the other slot data

press   Key and use   key to move Slot bar to the required Slot no. Slot (measured Data can be max 100 slots (measurements) on Each Battery Cell.

Fitting (Battery Change Estimation)

Battery Replacement Timing can be estimated roughly.

At TRACE mode, based on present Trend Curve, estimate when the Impedance Curve line may reach Upper 2 line.

Trend Curve , reaching time to upper 2 line, R- Squared value are displayed.

R-Squared value : indicates correspondence level between Estimate Trend Curve And actual data . 0 ~ 1 . When 1 or close to 1, indicates most stable, called Coefficient of Determination.

NOTE

Set Up of Upper 1(Warning) , Upper 2 (Fail) are designed as per Chapter 4.2 Limit on this manual data. The Lines can be adjusted as per User decision and set up Data as per Chapter D/B Input 5.9 procedure

Trend Curve- Fitting is just based on mathematic calculation of Impedance, Voltage and does not apply various and complicated factors, characteristics of battery which may affect battery health and battery life.

Fitting Curve is for reference only which manufacturer of the Analyzer may not guarantee the accuracy of the data. Ultimate decision is to be made by User.

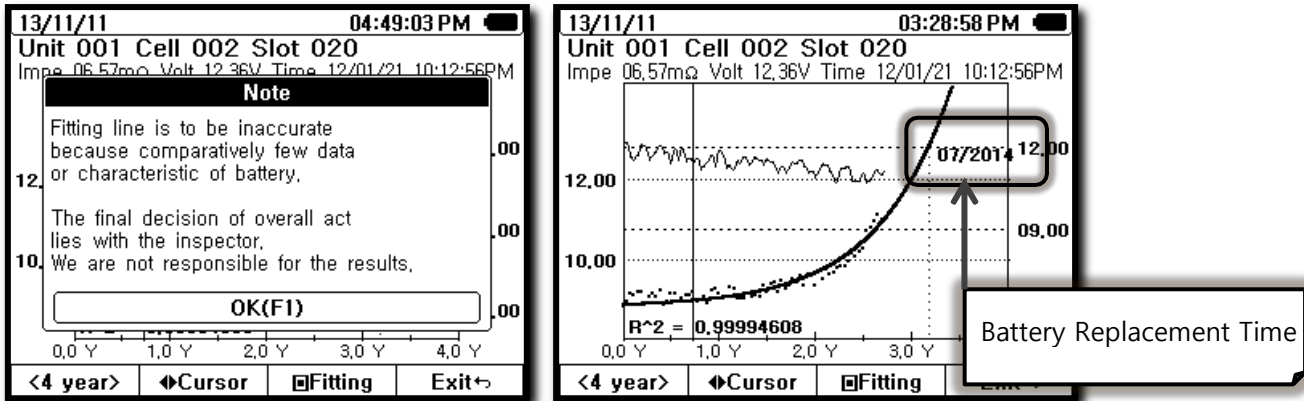

[TRACE – Fitting]

7. SOC (State of Charging) Capacity

7.1 SOC measurement

Measure OCV of Battery and display Remaining Capacity on LCD of unit

[Operation Procedure]

① Press Capacity Key

② Press F2 SOC... key

LCD display will be converted to SOC(%) on main display and Voltage Display at bottom.

③ Press F1 V/Cell key to select “Nominal Voltage” of battery

④ To gain Total Voltage value of Battery, press F2 Serial key and set number of battery in serial .

⑤ After total Voltage is measured, SOC is displayed on display .

- ⑥ When Auto HOLD mode, measurement data is recorded at memory in order

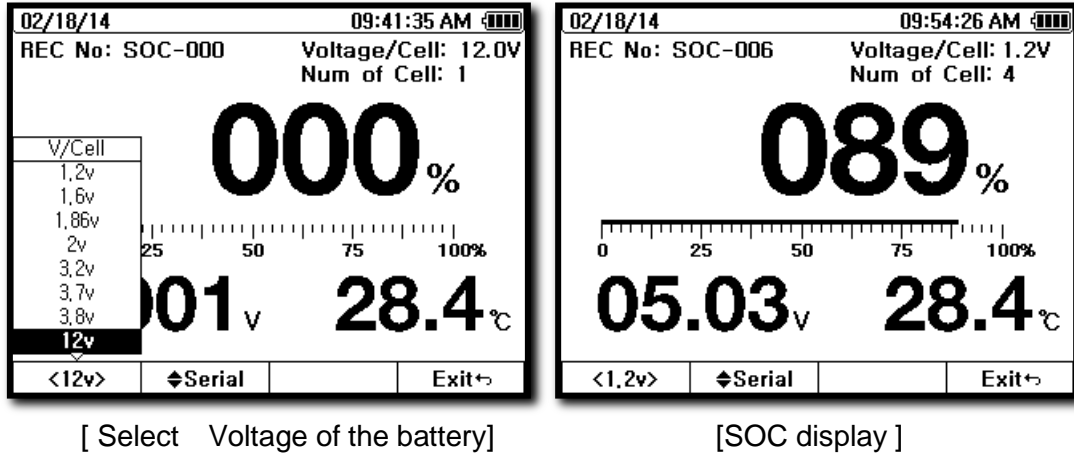

[Note]

To measure SOC, Battery should be separated from Charger or Loading Circuit. After separated, suggest to wait minimum 30 minutes for accurate measurement.

7.2 SOC Recall

At AUTO HOLD mode, SOC measurement data is automatically recorder in order of measurement. Record function can recall the recorded SOC data.

[Operation Procedure]

- ① Press **Capacity** key to enter Voltage measurement mode.
- ② Press **Record** key.
- ③ In Record, move Cursor to SOC Measurement with **▲** **▼** key and press **F1** **Select..** key to select. .

- ④ Recorded SOC data (#001~100) list is displayed.
- ⑤ Press , or key when need to erase
- ⑥ When delete Record, Confirmation message pop up . If yes, press key to erase completely

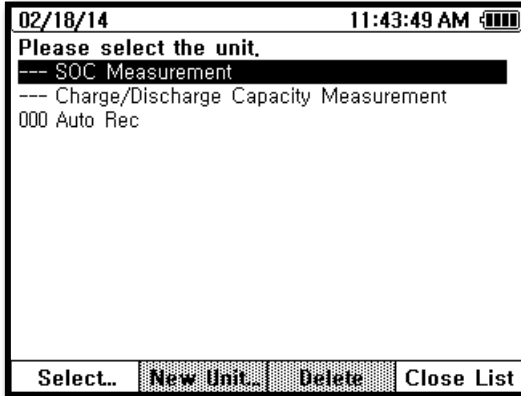

[Record select]

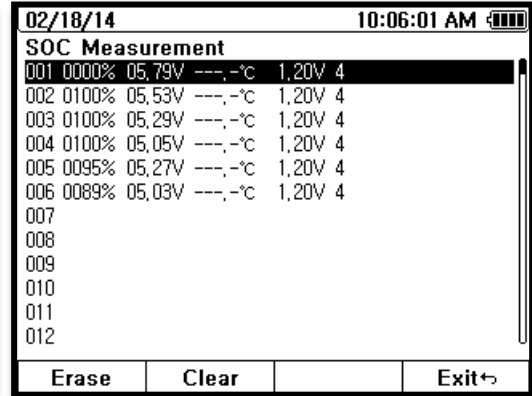

[SOC Record]

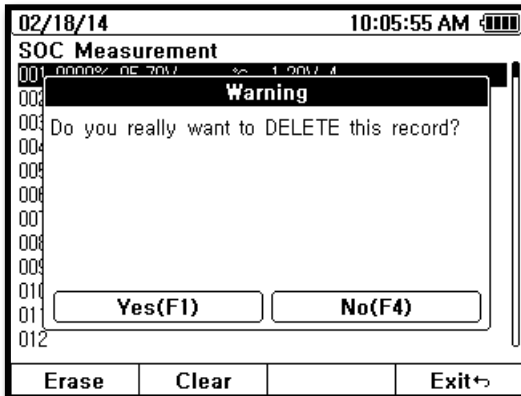

[SOC Record Erase]

8. Capacity Capacity

8.1 Preparation of Capacity measurement

At Voltage measurement mode, Capacity measurement is conducted - measure and record Voltage, Currents while Charging/Discharging.

Based on Recorded Voltage, Current, can measure Charging/Discharging capacity and calculate Efficiency (Charge Capacity versus Nominal Capacity)

[Measurement Procedure]

- ① To measure Charge Capacity, drain out battery completely.
- ② To measure Voltage, clip the Test Probe (Clip type) to the + - Battery Terminal.
- ③ Install DC Current Adapter to + terminal of Battery.
While Charging, Current measurement value shall display + data

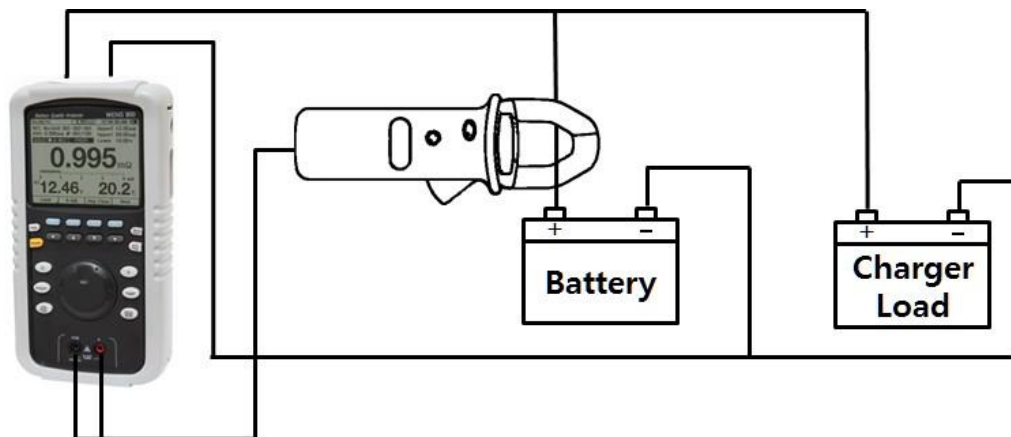

[Operation Procedure]

- ① Press Capacity key to enter Voltage measurement mode.
- ② Press F3 **Capacity...** key
Record setting, Battery Specification is shown on display.

③ Press **F1** **Prev** or **F2** **Next** key to move to desired setting item and press **F3** **Edit**↓

④ Set **F1** **↕Num** **F2** **↔Digit** **F3** **Range** with direction key

After set , press **F4** **Back**↵ key to exit.

This Setting procedure to be repeated **F1** **↕Num** , **F2** **↔Digit** and **F3** **Range** respectively.

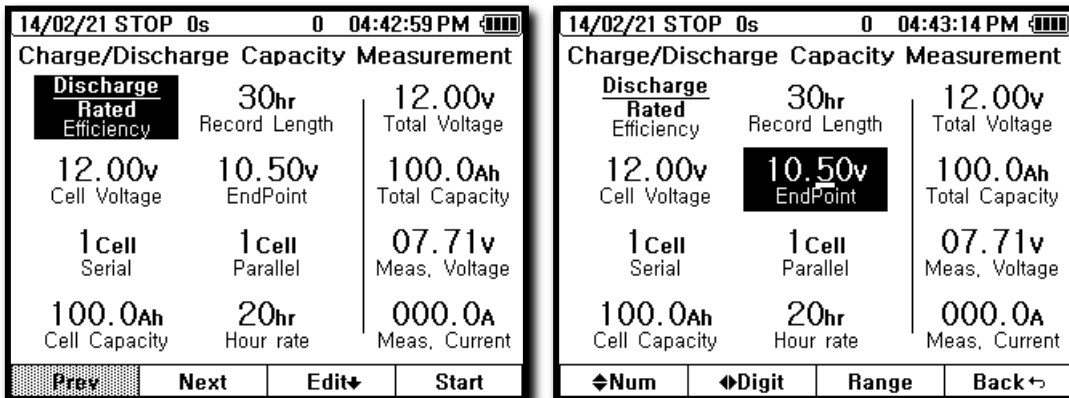

[Capacity measurement Set]

[Note]

The Analyzer conducts Measurement function only.

To measure Capacity, Charger/ Loader needs to connect to Analyzer

Charging Record Length is 3hrs ~ 30hrs . Sampling Rate can be adjusted between 1 sec ~ 10 sec (Max Sampling 10,800)

Max 100 data recorded . When start Record, Record Number provided automatically in order

8.2 Capacity measurement Capacity

After Setting, press F4 Start key to start Recording.

While Recording, "Auto Power Off" function and most keys except few softkey do not work.

When start measurement, measured data is automatically recorded at Capacity Measurement Record

Measurement Data can be displayed in View (Graph) or Data (Text):

Press F1 View key - Measurement in recording is displayed in Graphic format. Or Measurement is displayed in Data (Text) format- at Data format, average Current Value is additionally displayed.

When in Graph format, Sampling rate (time) can be adjusted automatically to display total record

When complete Full Charging on the discharged battery, separate Charger.

And connect with Loader to conduct Full Discharging (Drain Out)

This is 1 Cycle Charge/Discharge. With this 1 Cycle Charge/Discharge, can Gain Charging/Discharging Capacity and Efficiency.

When Press F4 Stop key or Record Setting Time is over, Recording is Stop



[Charging/Discharging Test]

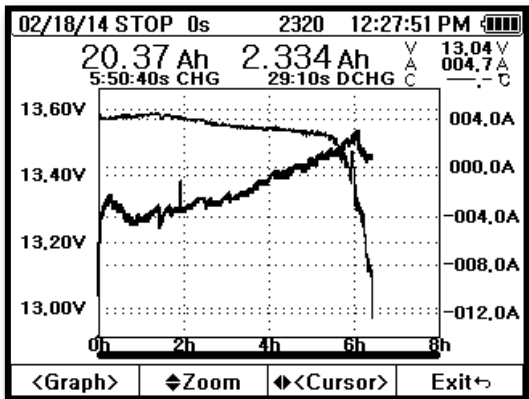

[Charging/Discharging Graph]

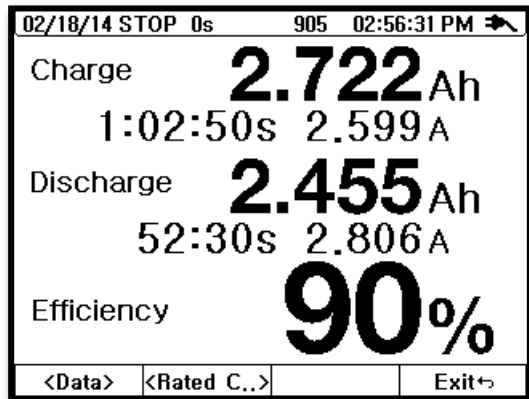

[Charging/Discharging Data]

8.3 Recall of Capacity measurement record

[Operation Procedure]

- ① Press **Capacity** key to enter Voltage measurement mode.
- ② Press **Record** key.
- ③ In Record, move Cursor to Capacity Measurement with **▲** **▼** key and press **F1** **Select..** key to select.
- ④ .In the SLOT list (# 001 ~#100) , move Cursor to the desired Recall Data with **▲** **▼** key and press **F3** **Recall** key.
- ⑤ Recorded Data is displayed in Graph. Use Zoom, Cursor to review.
- ⑥ Press **F4** **Back** key to return previous display.

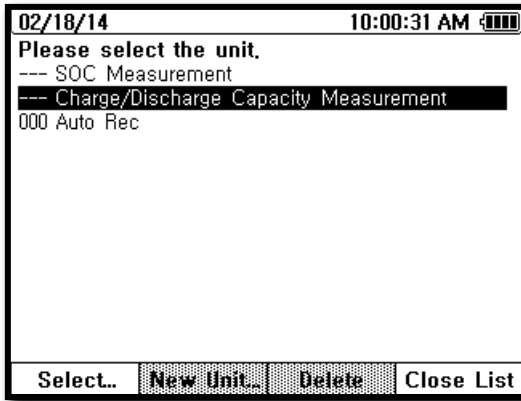

[Charging/Discharging selection]

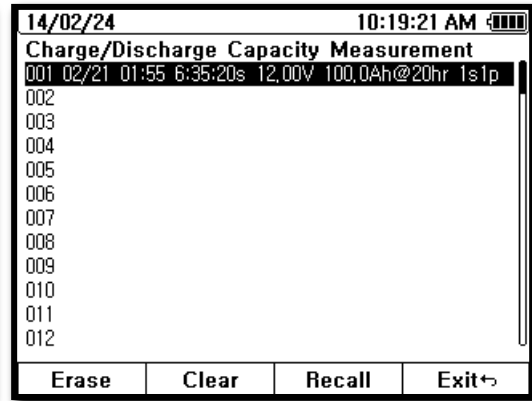

[Charging/Discharging Record]

8.4 ZOOM

When Recorded Data is accumulated in big amount, select specific Record area and magnify the area to review precisely.

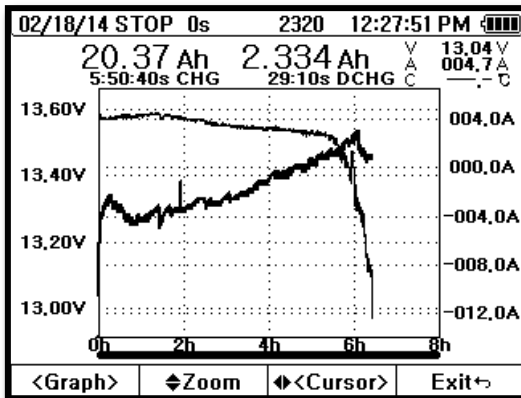

[Operation Procedure]

- ① Press **F2** **Zoom** key and set desired magnify ratio with **▲** **▼** key.
- ② Press **F3** **<<Cursor>** and use **◀** **▶** key to move Cursor to the desired point. Data of the desired point is displayed at Top of display.
- ③ Press **F4** **Exit↵** key to return to previous display.

8.5 Removal of Measurement Record

[Operation Procedure]

- ① Press **Capacity** key to enter Voltage measurement mode.
- ② Press **Record** key.
- ③ Move Cursor to Capacity Measurement with **▲** **▼** key and press **F1** **Select..** key to select. .
- ④ Move Cursor to the data in the List (# 001 ~ #100) with **▲** **▼**
- ⑤ Key. Press **F1** **Erase**
- ⑥ Press **F1** **Erase** , or **F2** **Clear** key when need to erase
- ⑦ Confirmation message is pop up. If yes, press **F1** **Yes(F1)** key to erase.
- ⑧ To erase all data, press **F2** **Clear** key. Confirmation message is pop up . If yes, press **F1** **Yes(F1)** key to clear all data completely

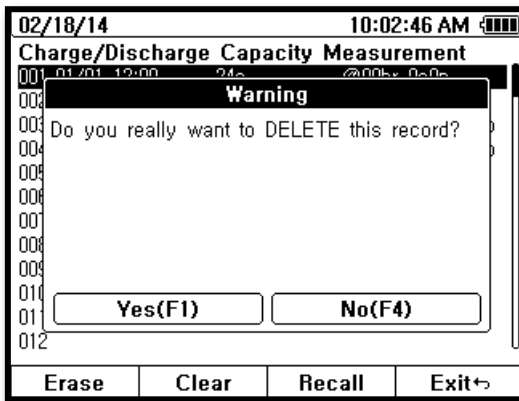

[Record Erase Confirmation]

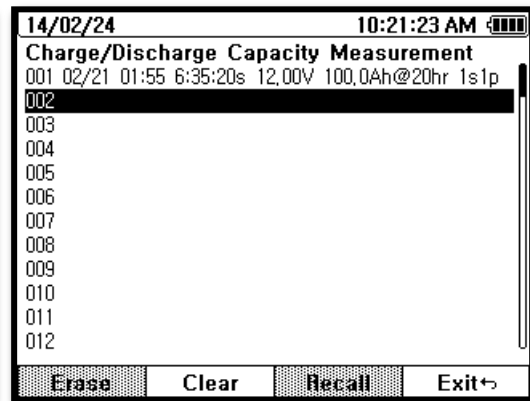

[Record Erase]

9. Data Base (D/B)



Data Base is the Reference Data (Initial Data) of Battery in management which evaluating and analyzing Battery Performance.

Reference data in Data Base is saved by Battery Type and Battery Manufacturer which is consist of Battery type, Battery Manufacturer, Impedance, Battery Voltage.

Reference Data saved in Data Base can use to Limit Set Up and Trace function in Analyzer as reference data which help judgment of battery deterioration

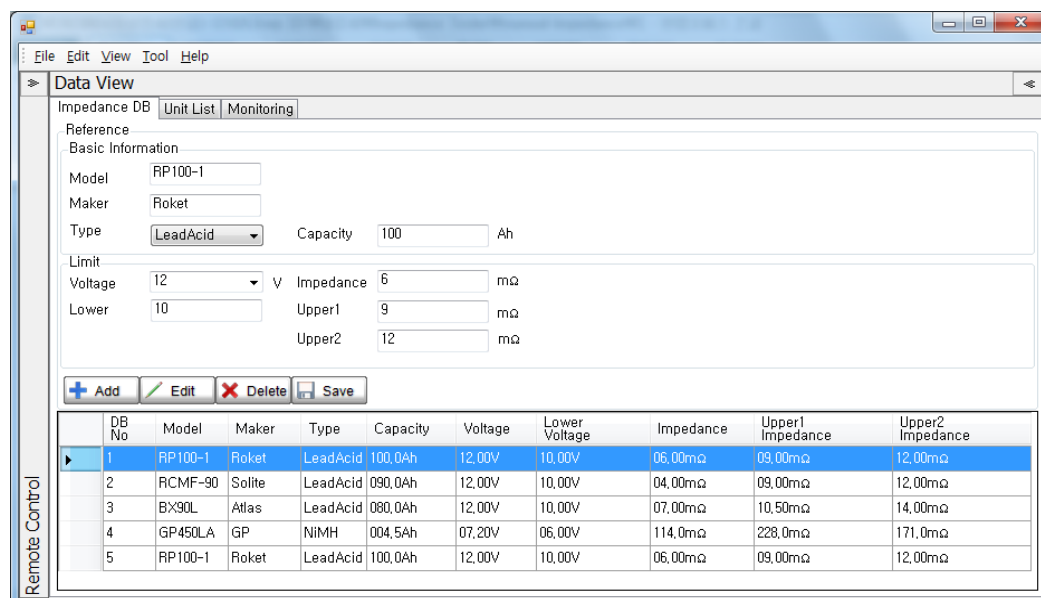

[Data Base Initial Display]

- Press Key for a shortly one time to enter DB mode.
- To observe DB Data, use key or Encoder Switch. DB address and Data displayed simultaneously.
- Press to set up DB Data as reference data and Limit is automatically set up.
- Release of DB function can be done by pressing other function key.
- Add or Delete of DB Data can be done through Computer only.

9.1 Saving Data Base





[Information in DB]

- DB No
- Battery Voltage
- Capacity
- Impedance
- Model Number
- Maker

9.2 Data Base function

- Before analyze Battery, recall the Reference Data of Battery in management saved in DB and use as Battery Basic Specifications.
- At Limit, press F1  "Call" key to automatically convert to DB mode and set up DB data as Reference data by using Up/Down key. Then Limit is working.
- In Analyzer function, data measured periodically are saved by unit. The DB is used as reference data when evaluate Data Change status or Trend of Battery Deterioration.

9.3 Recall DB Application at Limit

- At Limit function, without input Maximum Limit and Minimum Limit, Recall the Data in saved in DB and use as reference to set up Limit.
- At Limit function, press F2  "Recall" to activate whole contents of DB.
- Use Up/Down   or Encode key to select desired "DB No" and press  "CALL" key
- DB is used as reference data of Limit setting.

9.4 DB Application at TRACE in Analyze mode

- In Analyzer mode, use DB data (reference data saved by each unit) to judge Battery Deterioration with Trace.
- Reference data is saved at Record Unit 의 “000” cell of Record unit.
- Input procedure of reference DB is available only through PC program .

9.5 Input and Erase of DB

Input, erase and modification of DB in the Analyzer is available only through PC Program.

- Load PC Program on Computer.
- Connect the Analyzer (mini USB port) to Computer with USB cable.
- Click “ON” on PC Program Initial Screen .
- Click “ Impedance Data Base” in the menu
- When add DB data, input battery data in “ Basic Information” in order and click“ADD” to complete data Input.
- When correct the DB Data already saved, first Click the DB No. Second, correct the data in “ Basic Information” and press “Edit” to complete the correction.
- When delete the DB Data, click DB no and click “ Delete”
- When input DB data, DB No is automatically created.
- Input Data: Battery Type, Capacity, Model Number, Voltage, Impedance, Manufacturer.

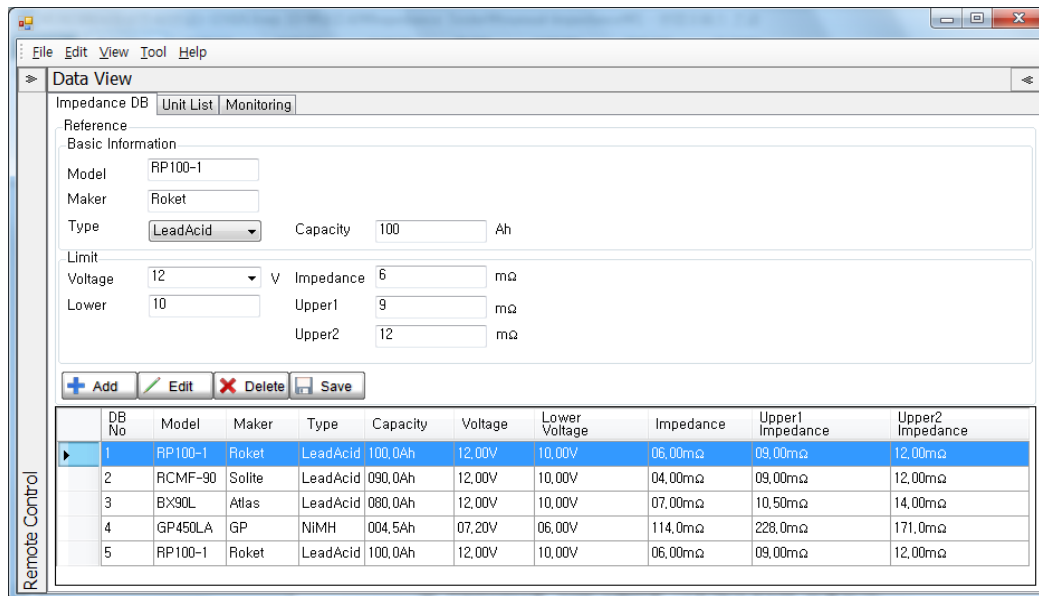

[Data Base Input Display]

10 . Auxiliary Functions







10.1 Auto Power Off

The function is activated when the Analyzer is working by Battery installed inside. This function does not activate if the Analyzer is powered through AC Power adapter. When user forgot to power off of the Analyzer, Auto Power Off function works to save the Battery Power Consumption and prevent shorten battery life from complete discharge.

- Works only when Battery is used as power of Analyzer. When there is no input signal within the preset time, power is automatically off.
- Auto Power Off time can be set among OFF, minimum 10 minutes to maximum 1 hour at User mode.
- When use power through AC Adapter, Auto Power Off function is automatically cut off.
- Initial set up (Default) is set up with 30 minutes. User can set up desired time at User mode.

- When use Analyzer long time and when the Auto Power Off function does not need, set up OFF to release the function.
- When Power On again while Auto Power Off is working, the Auto Power Off setting does not change.

[Operation Procedure]

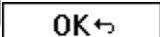

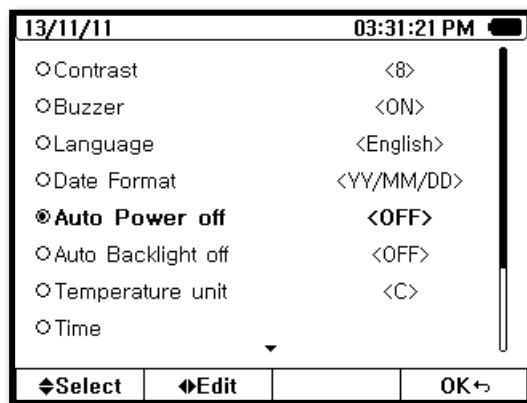

- Press DB/  key for longer than 2 seconds to enter User mode.
- Select Auto Power Off with   keys.
- Use   to select Auto Power Off time.
- After selected, Press Enter Key or   key to set.
- If press Exit key, Setting is completed and proceed to previous measurement mode.



10.2 Low Battery Warning

Remaining Battery power of NiMH Rechargeable Battery Pack installed inside of Analyzer is displayed in BARGRAPH form at Upper Right corner of the Analyzer. This function gives information of low battery to user to prepare inconvenience from battery power shortage in advance.

[Remaining Battery Indication]

Indication	Status
	NiMH Battery is fully charged.
	After continuous use approx. 1 hours.
	After continuous use approx. 3~4 hours.
	After continuous use approx. 5~6 hours.
	No Remaining Power. Beeper sound.

- When use Battery or AC Adaptor, the Symbol of Battery or AC Adaptor is displayed on Upper Right on LCD Screen.
- If connected with AC Adaptor, Battery Symbol is disappeared.
- If disconnect AC Adaptor, Battery symbol is appeared.

10.3 User Mode









User can set up many functions as needed.

[User Set up Functions]

- Contrast
- Buzzer On/Off
- Language
- Date Format
- Auto Power Off

- Temperature Unit
- Time
- Factory Reset
- Device Information
- Auto Power OFF

[Operation Procedure]

- ① Press DB/User  key longer than 2 seconds to enter User mode.
- ② Select function to set by Up/Down   keys.
- ③ After function is selected, Change setting by Left/Right   keys or Encoder Switch.
- ④ After setting is changed, press Enter key to complete Setting and Save.
- ⑤ Enter F4  Exit Key to enter Measurement mode.

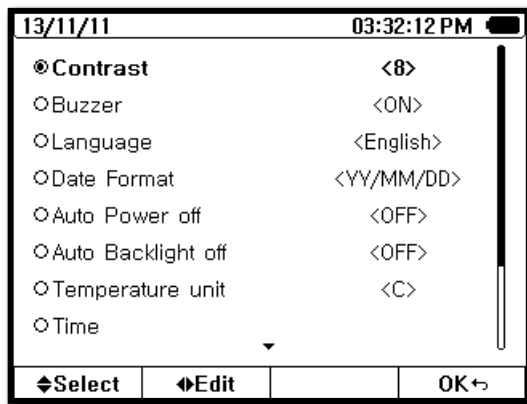

[User Menu Initial Display]

[Contrast Adjust]

- Set Brightness of LCD Screen: Can change between 1 ~ 15 steps..
- Initial Set Up (Default) is set in 8 steps

[Key Buzzer]

- When Function key is pressed, Beeper sound
- Initial Set up (Default) is ON.

- Can change to OFF.
- When operates Key Scan, Over Voltage, Limit, Beeper activated.
- No Beeper symbol displayed on LCD Screen.

[Language]

- Help language set up.
- Initial Set Up is English, Korean

[Date Format]

- Display Method: Year, Month, Day
- Initial Set up is Year –Month -Day.
- User can change to Day -Month-Year

[Time Setting]

- Time Setting: Hour-Minute-Second.

[Auto Power OFF]

- Auto Power Off time setting: OFF, between 10 min ~1 hour
- Initial Setting (Default) set as 30 minutes.

[Temperature Unit]

- Temperature Unit can be selected °C/°F.
- Initial (default) set up is °C.

[Device Information]

- System Information loaded.
- F/W Version No
- System Format

[Factory Reset]





- Initiate All System of the Analyzer while using: Operates at User mode.
- When this function is activated, convert to Factory Mode.

10.4 HELP

Brief Information on each functions are described on HELP mode.

HELP function is to help User to understand Measurement Functions or other functions.

[Operation Procedure]

- Press Help  key to convert to HELP mode and Explanation is displayed on LCD Screen.
- If HELP has multiple pages. Use Up/Down   key or Encoder Switch to read.
- To release HELP. Press Exit key or other function keys.
- HELP mode support multi language. Select Language at USER mode.
press  key longer than 2 seconds to enter and select Language.

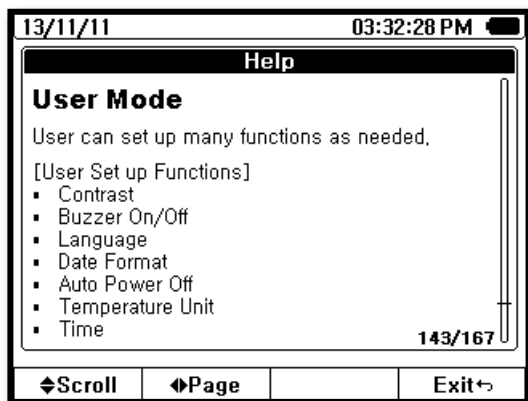

10.5 Others

[Warning Display]

- In Auto Ranging mode, when input over M
- In Manual Range mode, when Over Voltage.

[Power Key]

- Press Power ON/OFF  key longer than 2 seconds.





[Encoder Switch]

- Rotate to Clock direction or reverser clock direction as Left / Right  direction key function.
- ENTER: push down. Enter Key (Confirmation of Function Setting)

[Left/Right/Up/Down direction Key]

- Find function or change the setting value.
- Use when Limit or User Mode setting.

[Auto/Manual]

- When change from Auto ranging to Manual ranging mode, Press  key for a short time.
- While in Manual Ranging, press “Auto/Range”  key shortly to move the measuring range. One range move per one time press (short time) of Auto/Range  key.
- When change from Manual Ranging to Auto ranging, press the Key  longer than 2 seconds.

[Note]

- Impedance: Auto /Manual Ranging
- Voltage: Auto / Manual ranging (Initial Set at Auto ranging)
- Currents: 400 mA(Fix), 40A/400A(Manual)
- Temperature : Fix Range

[HOLD/ Auto Hold – Auto Record]



- Press Key (for a short time) to enter HOLD. To release HOLD, press Key for a short time.
- To enter Auto Hold, press key for longer than 2 seconds.
- To release from AutoHold, press key for longer than 2 seconds,

[F1~F4]



- Subsidiary Function key. Use when Impedance, Voltage, Analyzer, Logger, User, Record, Replay mode.

[Adapter]

- Main Power supply of the Analyzer is NiMH (7.2V) battery. Use 2 x (3.6 V) battery Packs on the Analyzer. When Battery Power is not available, AC Adapter (12V/1A) is also used as main power supply.
- When insert AC Adapter to the Analyzer, Operation is done by Adapter power supply, while maintain power is supplied to Battery to continue Charging.
- When the Analyzer is operated by AC Adapter, Auto Power OFF (Default) function is released.

11. PC Interface Program

11.1 Description

By connecting USB cable, The Analyzer can transmit the Measured Data in internal memory of Analyzer or Data in present measurement to Computer at real time. Through Compute, Available Data Management, Data Analysis, Program Update, input Referenced Data to Data Base in Analyzer. In order to communicate between Analyzer and Computer, following Software set up procedure is required. Software Program can be set up through supplied Software CD or Download Software Program from manufacturer website.

11.2 Suggested Operation Environments

- OS Windows XP, Vista, 7
- True Color(32 bit) or more
- Memory 128 MB or more
- HDD capacity 20MByte or more
- Interface USB Version 2.0

11.3 Connection between Analyzer and PC

Before connect Analyzer with Computer, please install PC Interface program of Analyzer to PC

- In order to communicate between Computer and Analyzer, USB mini type socket is provided at below the AC Adapter power port at right side of Analyzer.
- Before USB communication, Driver should be installed at Computer.
- USB cable is recommended to use as supplied with the Analyzer. When use other USB cable, please make sure that cable should have same type, specifications of original USB cable supplied from manufacturer.

11.4 PC Interface Software Installation Procedure

- ◆ If insert Interface Software (CD) to PC , following Selection menu is shown

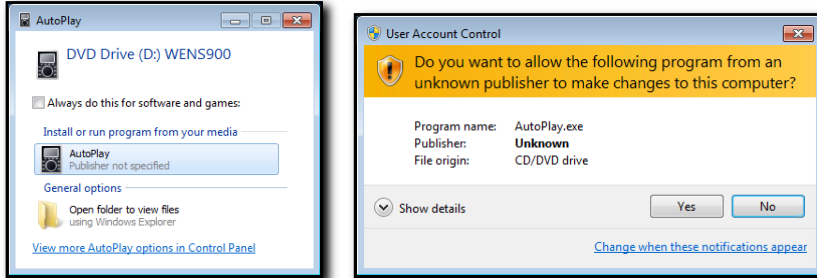

- ◆ Select “Auto Play” User Authorization Click “ Yes”

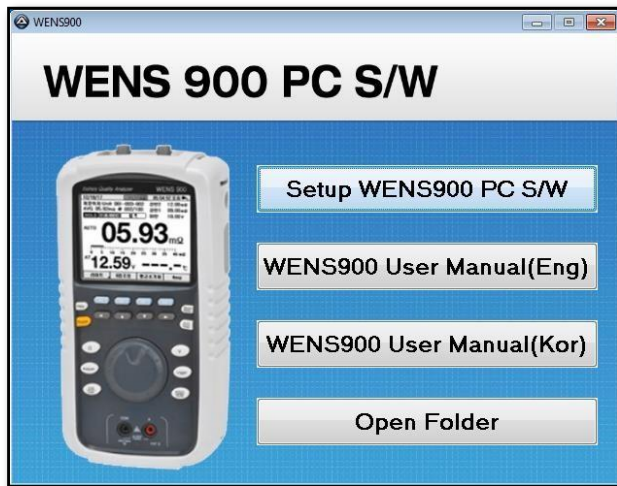

- ◆ Click “ Setup WENS 900 PC S/W “

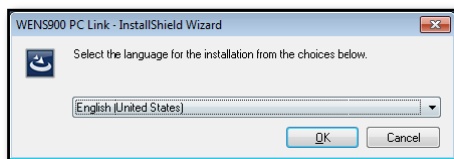

- ◆ Select language “ English “

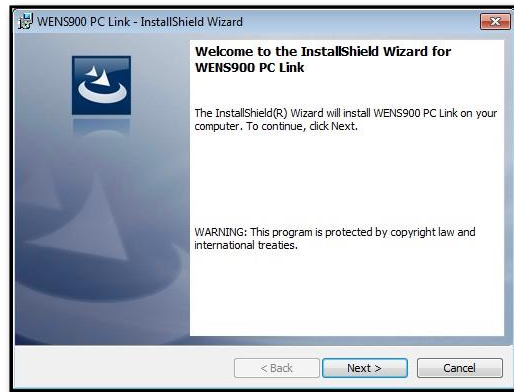
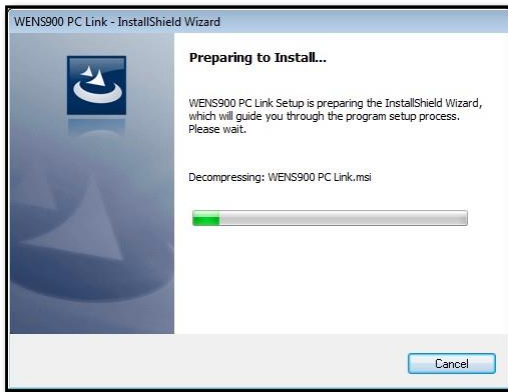

◆ Click “Next”

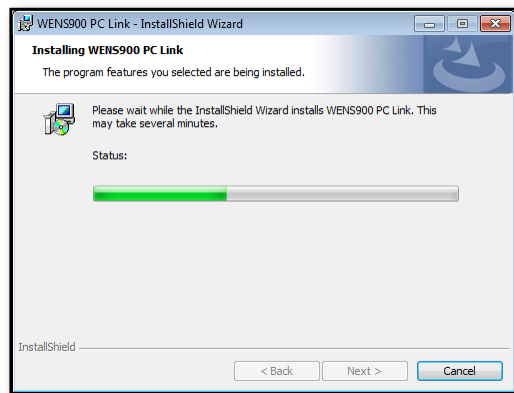
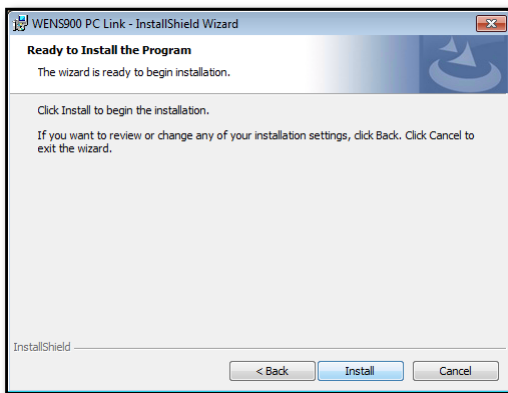

◆After Click “Install” , wait for a moment.

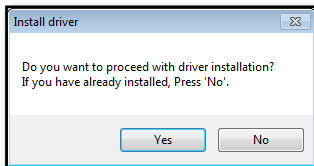

If 1st installation, click “Yes”. Then, Installation Driver starts

If already installed , click No “No”

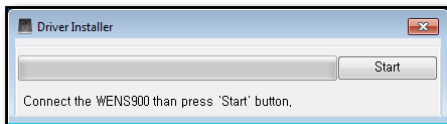

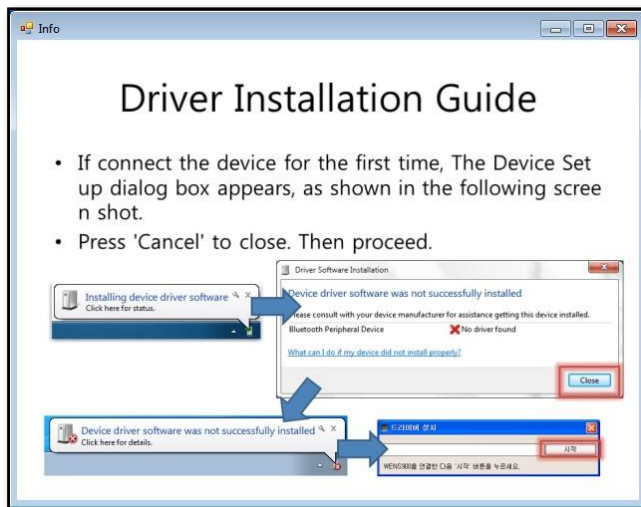

- ◆ If connect the system first time, Driver Installation starts automatically at Window. Be sure to close other open windows. Otherwise Driver installation may be failed.

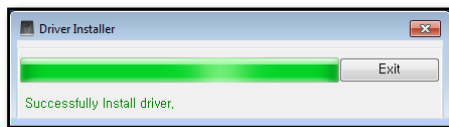

- ◆ If click “ Start “ , after a moment, Driver Installation is completed.

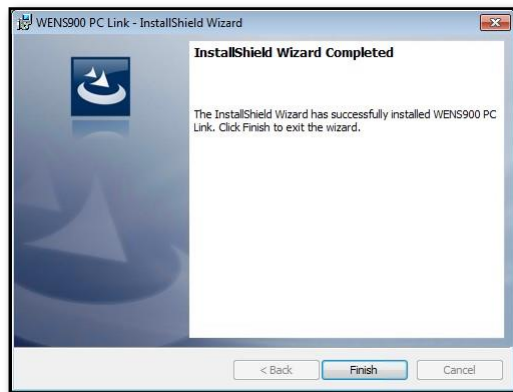

- ◆ Click finish “Finish” , then, Software installation is finished.



- ◆ ICON will be made at bottom of PC display Screen.

11.5 Removal of Software

If Analyzer is working while connected with Application Software, Separate it from Analyzer and remove it.

- ☞ [Start]-[Control Board] select [Program Add or Delete]
- ☞ Select [900 Software] and click [Delete]

11.6 How to use Software

[Connection between Analyzer and Computer]

- ① Connect USB cable between Analyzer and Computer
- ② Double Click the SOFTWARE Icon on Computer Display screen.
Then, Software Initial Screen will be displayed.

- ③ Power On  Analyzer

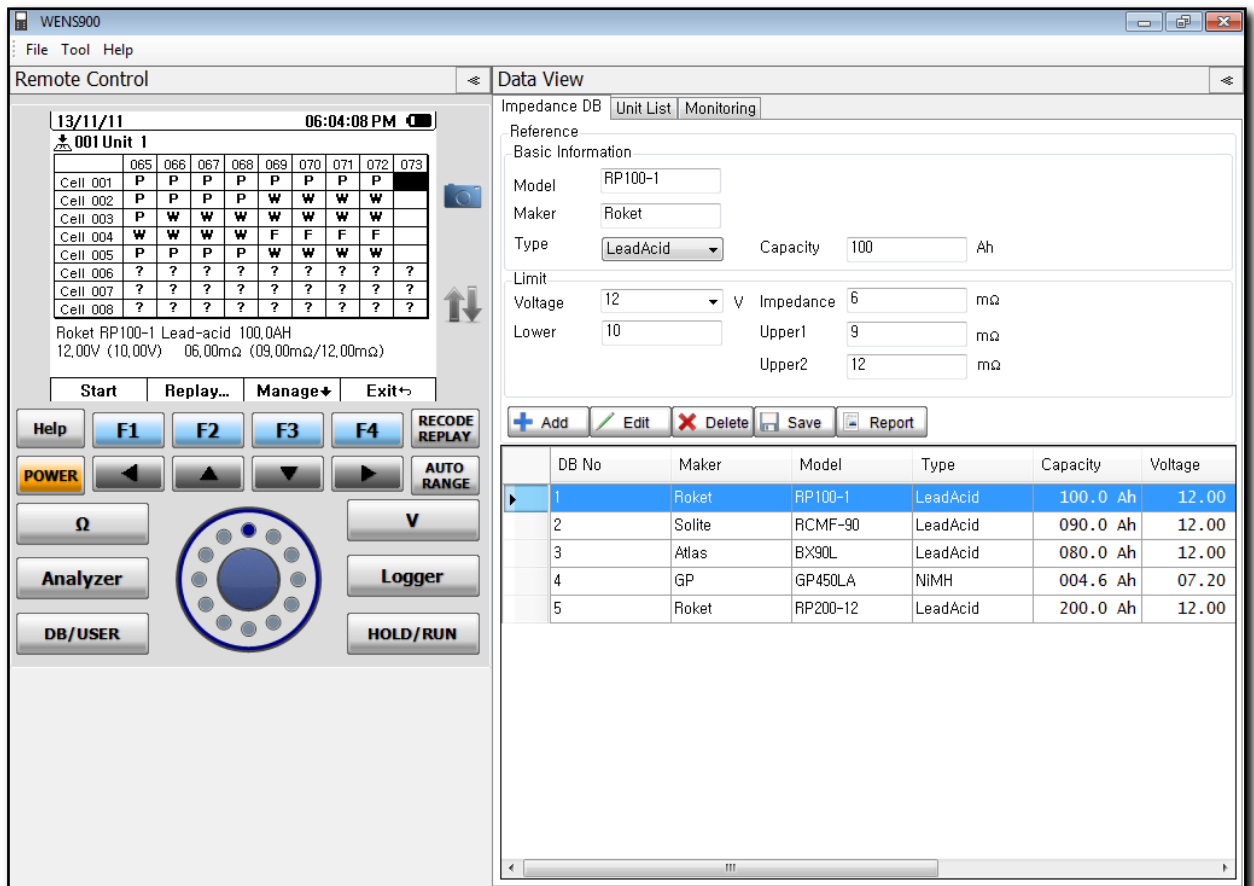

[Note]

- If USB cable is not connected, An Error comes
- When PC Interface is working, Auto Power Off function on Analyzer is shut off.



[Initial Screen]



Interface Program Structure

- Left half block of window is for Remote Control (Control panel)
 LCD screen of present Analyzer is displayed simultaneously at real time base.
 Lower block is buttons same as Analyzer.
- Right half block of window is D/B, Measurement Record, menus for PC Log of Analyzer (Data Panel)
- When either Control Panel or Data Panel does not need to display, user can Remove or Recall it with   on Display

1) Remote Control

- PC Interface can control Function of Analyzer same as Analyzer can control function

of Computer program

- Screen Capture of Present display is available if click  at upper Left of Computer Screen.
- Check Interface Status of Data:  at Middle Left area of Computer indicates LCD screen of present Analyzer is displayed at Present PC Screen. simultaneously at real time base.

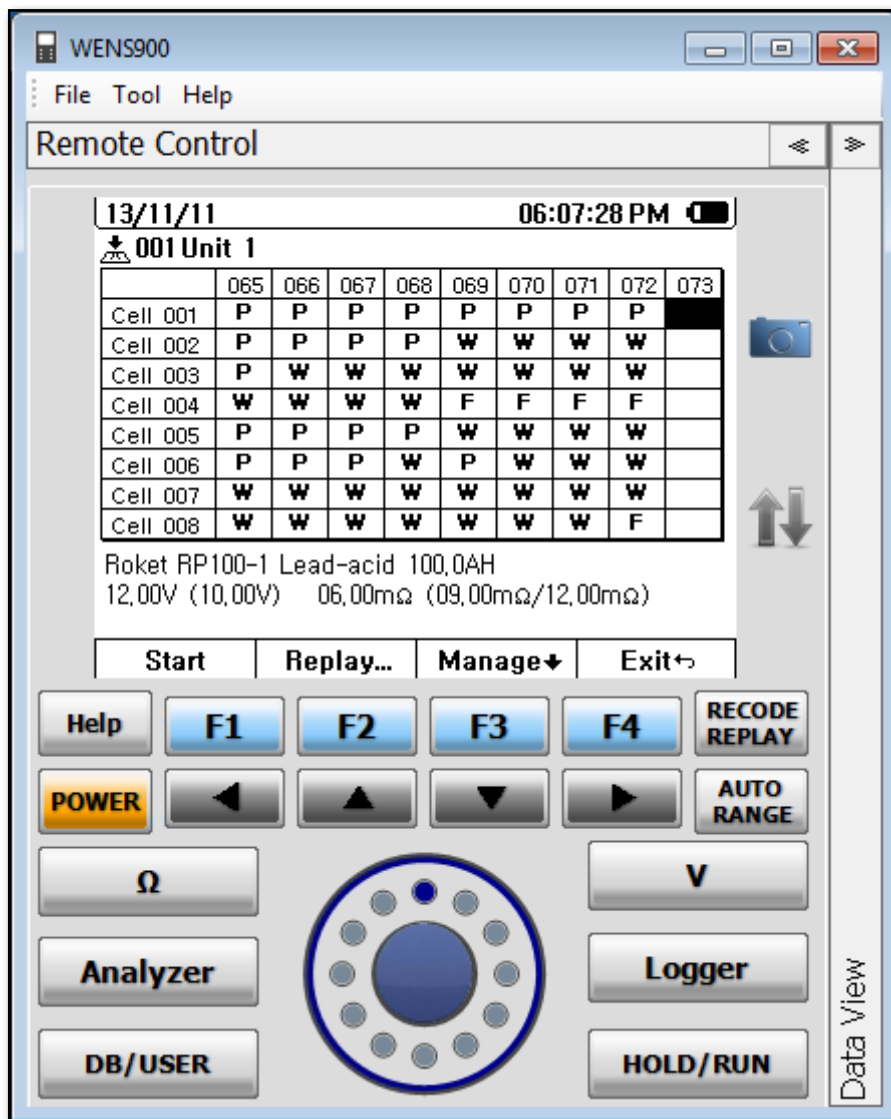

[Control Panel]

2) Management of Recorded Data

Manage the measured data and store. Maximum 7,530,000 data is available to store.

Data is stored and managed as below

- Data of Unit (Name,Reference, Battery D/B)
- Addition, Edit ,Delete of Unit
- Data Display recorded on Unit (Impedance, Voltages, Temperature,Comparator result)
- Delete of record on Unit (individual delete, vacant)

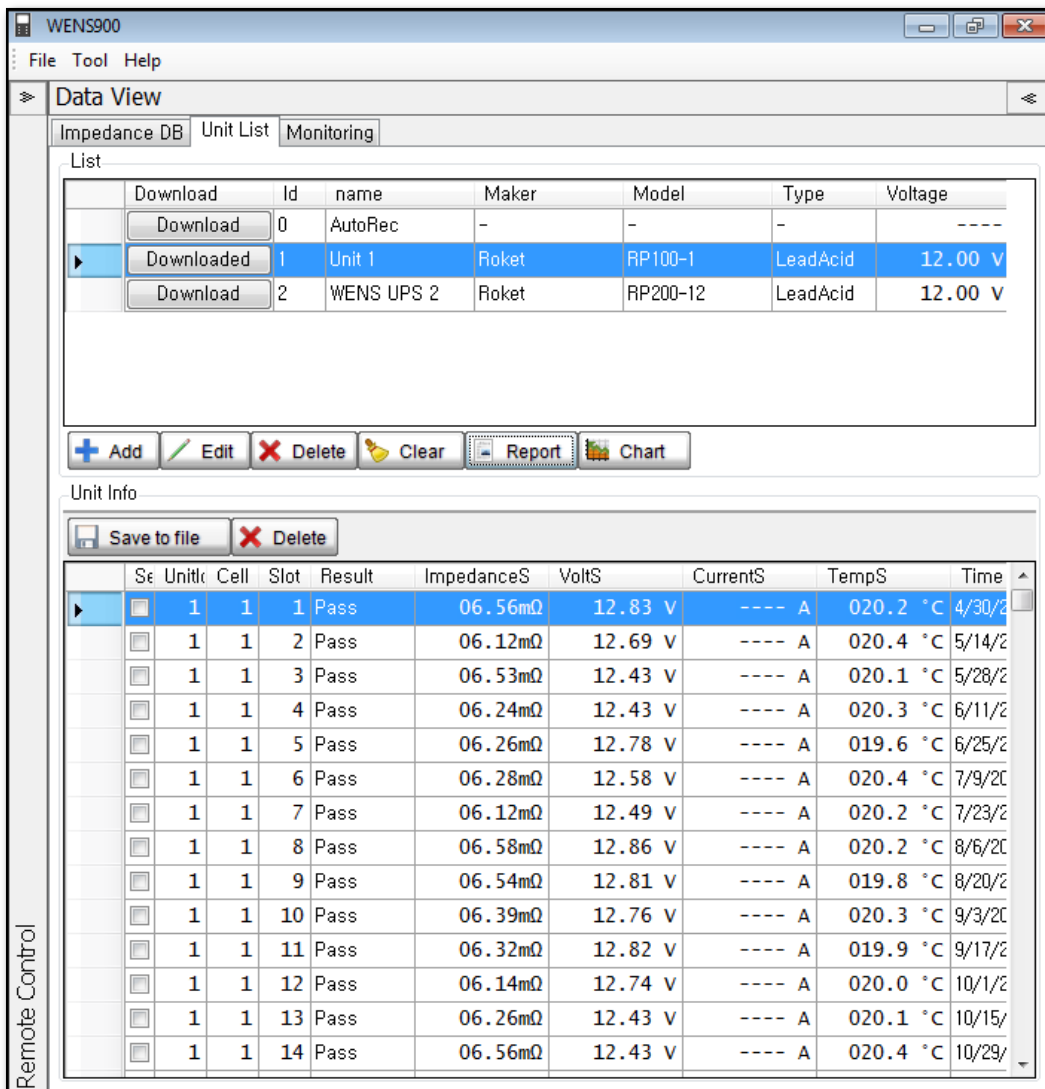

- Measurement Data - Saved in Excel file

[Recoded Data Management]

3) Data Base

To judge battery deterioration and Battery aging with the measured data, can input and modify Battery Manufacturer, Battery Type, Capacity, Model number, Voltages, Impedance etc.

[Available functions at PC Program]

- Data Base Add, Edit , Delete

- Data Base into Excel file
- Data Base number: Maximum 200

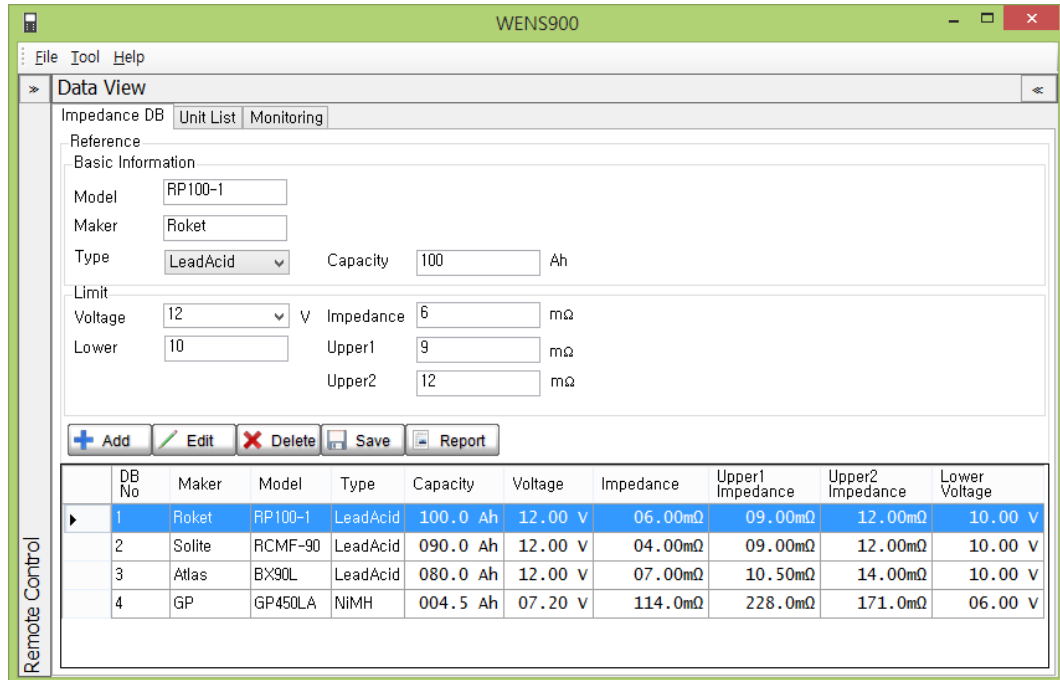

4) Monitor

While Analyzer and Computer is connected, measured Data in the Analyzer transmit at real time base to Computer and display or save the Trend of Value in Graphic format.

- Measurement Value on Analyzer displayed same on Computer monitor.
- Measurement and Calculation value are displayed in Index.
- Measurement Value display in Graphic at real time base.
- 1 ~ 4 Graphs can be selected to draw. Maximum 4 Graphs can be drawn simultaneously.
- Drawn Graphs are available to save at Computer.

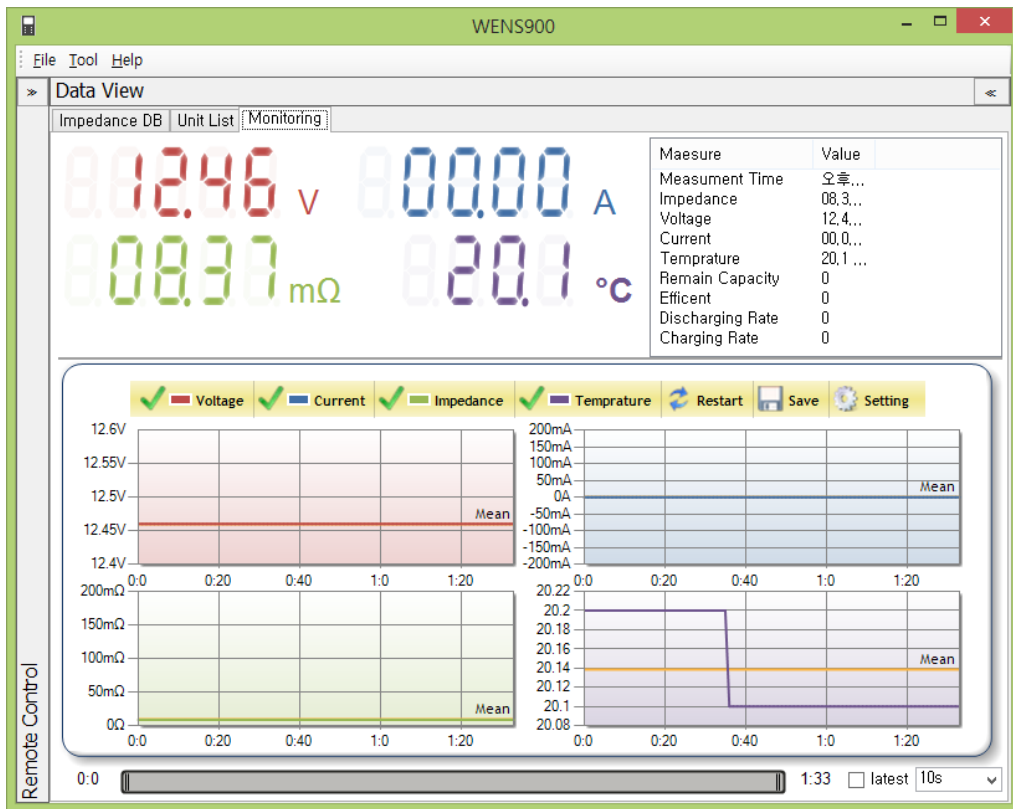



[PC Monitor]

5) Report

a) Report  Report

D/B or Measurement Data can be printed in Report Format already designed.

Following Data can be REPORT.

- Battery D/B report
Press  Report button on D/B Edit Screen
- One Time (Slot) report of Unit
Select Unit and press  Report button.

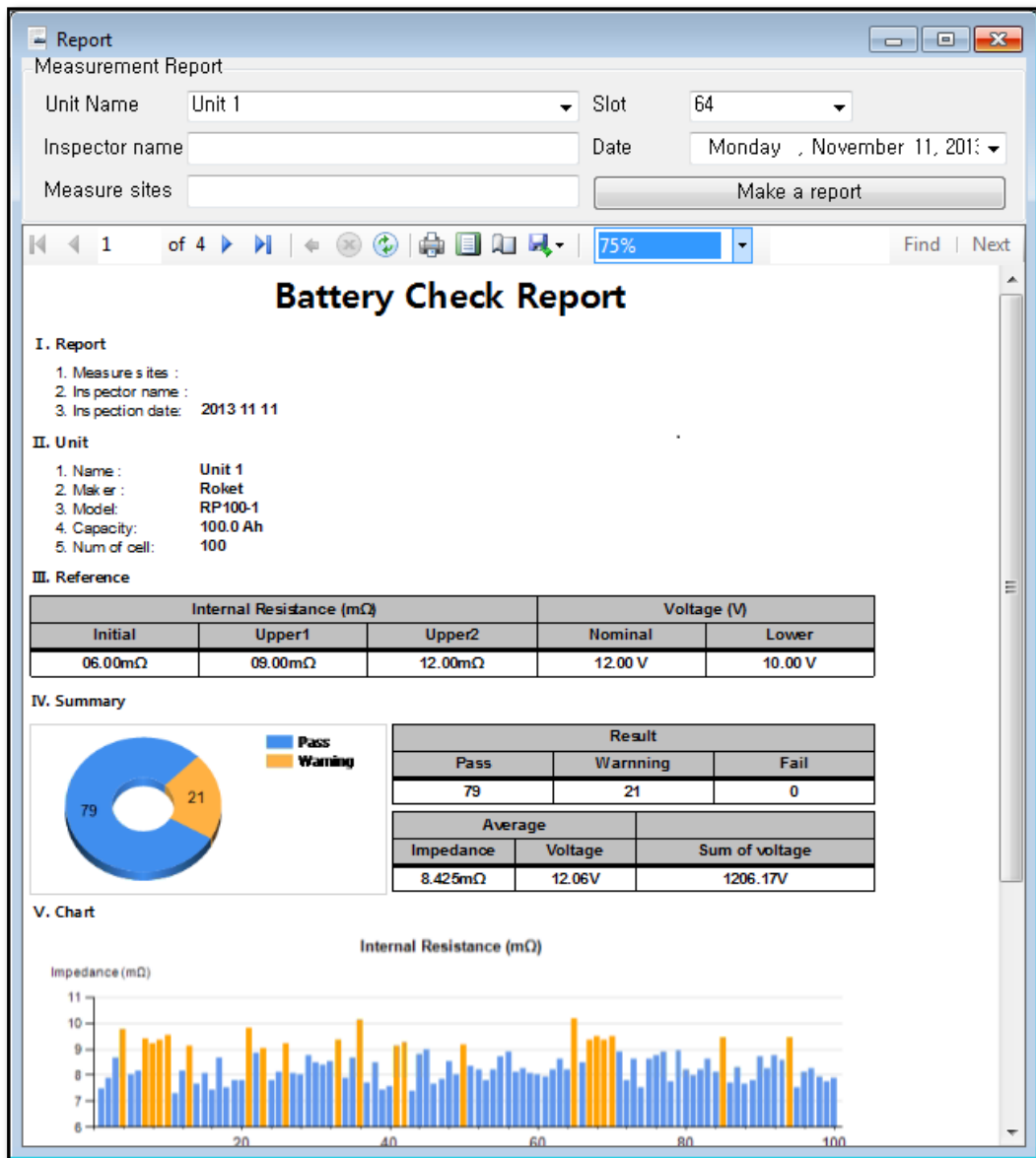

[Battery Measurement Report]

B) Chart  Chart

Accumulated Measurement Data can be displayed in 2D or 3D Chart. Press  button.

Following Data can be displayed in Chart.

- Measurement Data Change of individual Cell
- Comparison Chart among cell to Cell in same Unit (One time SLOT)
- After select Unit, Comparison Cell to Cell, Measurement Data Change of

individual cell can be displayed same time in 3D Chart(30 cell x 10 measurements)

- If Mouse indicates specific Cell, the Measurement Data of the Cell is available to Display.
- Comparator Measurement Result (Pass, Warning, Fail)display in different Color

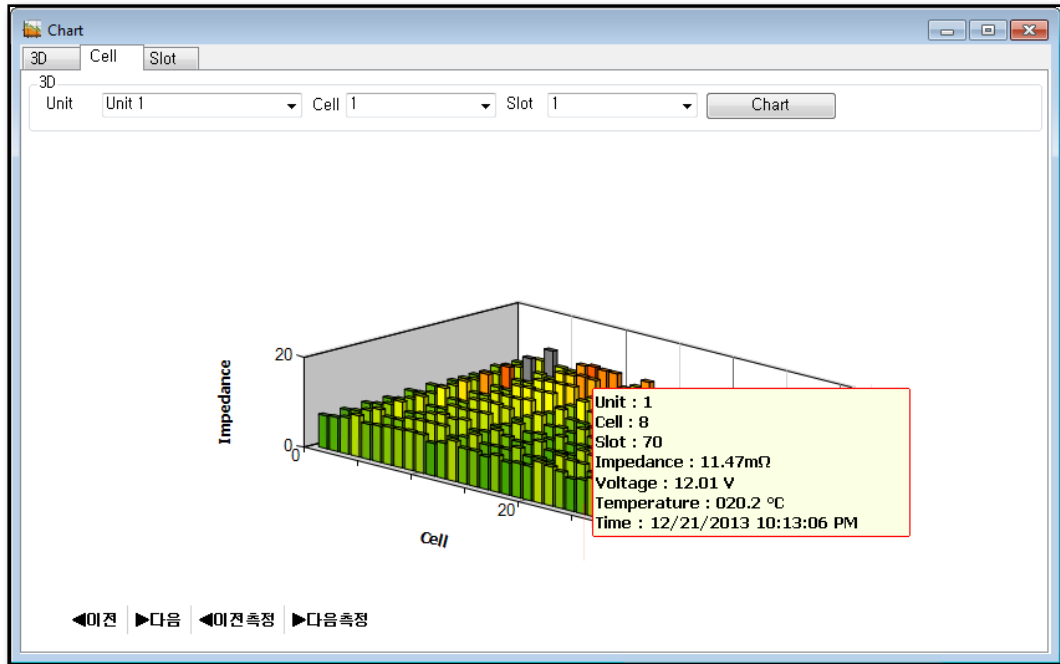

[3D Chart]

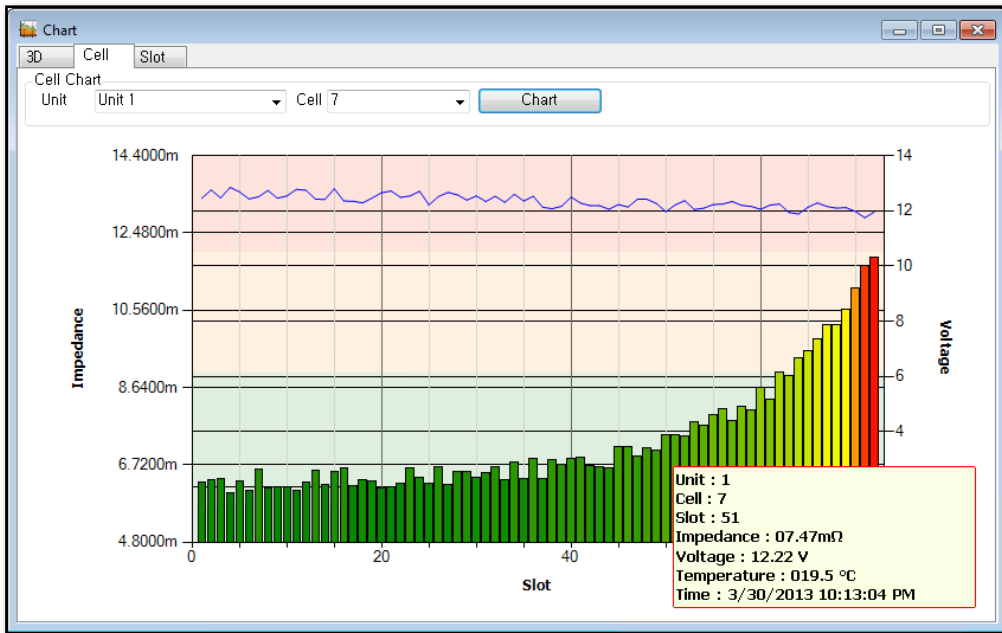

[Cell Chart]



[Measurement Time Chart]

11.7 How to finish Software

Click X button  at Upper Right of Screen. Then, PC Program screen will be disappeared and Connection with Analyzer is finished.

12. Specifications

12.1 General Specifications

1) Special Features and Functions

- Battery Internal Resistance (Impedance) measurement.
- Battery Terminal Voltage (DC Voltage measurement)
- Discharging Current (DC Current) measurement.
- Temperature measurement (Ambient Temperature around Battery Terminals)
- 4-Terminal measurement: Impedance, Voltage, simultaneous measurement and independent measurement.
- One measurement enables to judge Battery Deterioration and Replacement Time.
- Battery Capacity calculation
- SD card storage capacity enables to manage up to max 7,530,000 data management.
- Simultaneous Measurement and Battery Status analysis(Data and Graphic display)
- Battery Trend Analysis (Impedance, Voltage)
- Auto Hold and Data Storage
- Enhanced Analysis Accuracy from Data Base(Reference, Background)
- Limit function (Comparator) of Impedance and Voltage
- Help function

2) General Specifications

- 3.8" Graphic Mono LCD Module (320 x 240 pixel)
- USB Client
- Input Method : Differential (Impedance, Voltages, Temperature and DC Current measurement)
- Sampling Time: 10/sec
- Battery: 7.2V NiMH / 2.7A (2 x 3.6V NiMH/2.7A battery pack)
- Internal Battery Use time after full charge : Approximate 6 hours
- Internal Battery Full Charging Time : Approximately 6 hours.
- AC Adapter: 100V ~ 240V/AC (Automatic) Output DC12V/1A.
- Operation Temperature: 0°C ~ 40°C, below 80% RH (No Dew)
- Storage Temp. Humidity: -10°C ~ 50°C, below 80% RH (No Dew)
- Temperature Coefficient: 0.05 x (accuracy) / °C (below 18 °C or above 28 °C)
- Max Input Voltage "+" Measurement Terminal (Electrodes) \Leftrightarrow "-" Between Electrodes: Max DC 300V
- EMC : EN61326:1997+A1:1998+A2:2001+A3:2003
- Safety Standard : EN61010-1: 2001 Pollution degree 2, Measurement Category II (Estimated Over Voltage 300V)
- Dimensions: 107 mm(W) x 220 mm(H) x 55 mm(D)/4.2" x 8.3 " x 2.2 "
- Weight (Main Unit only): 1.0 kg / 2.2 lbs

12.2 Electrical Specifications

[Guaranteed Accuracy Temperature Condition]

- Accuracy is valid within 18°C ~ 28°C (64°F ~ 82°F), Relative Humidity Max 80% for 1 year.

□ Accuracy Specifications: \pm ([% of reading] + [Last digit number]).

• **Impedance (Internal Resistance) (Auto/Manual)**

Range	Resolution	Current	Accuracy
+ 4m Ω	1u Ω	100mA	$\pm 1.0 \%rdg \pm 50$ dgts (100 u Ω ~ 4m Ω)
40m Ω	10u Ω	100mA	$\pm 0.8 \%rdg \pm 10$ dgts
400m Ω	100u Ω	10mA	
4 Ω	1m Ω	10mA	

+ 4m Ω Range is Manual Ranging only.

Other Ranges are AUTO/Manual Ranging

- Measurement Current Accuracy: $\pm 10\%$
- Measurement Current Frequency: 1 kHz ± 30 Hz

When measurement “ Impedance “ Voltage of the measuring Battery should be under 100V DC. Between 100V ~ 150V. Impedance can be measured with Warning Sound. If Battery is over 150V, the protection circuit is off and Impedance measurement function shut off.

• **DC Voltage (Auto / Manual)**

Range	Max Display	Resolution	Accuracy
4V	± 4	1 mV	$\pm 0.5\%rdg \pm 5$ dgts
40V	± 40	10mV	
300V	± 300	100 mV	

• Temperature

Measured temperature indicates battery terminal temperature but not the internal battery temperature or electrolyte temperature

Range	Resolution	Accuracy
-10 $^{\circ}$ C ~ 100 $^{\circ}$ C / 14 $^{\circ}$ F ~ 212 $^{\circ}$ F	0.1 $^{\circ}$ C or 0.1 $^{\circ}$ F	N. S.

- **Current DC**

- Measurement through external Current Probe * Optional Item

Range	Output Reading	Resolution	Accuracy
40A DC	DC 1mV/A	0.01A	+/- 0.5% + specified on CT Accuracy
400A DC	DC 1mV/A	0.1A	+/- 0.5% + specified on CT Accuracy

Measurement Range and Measurement Reading accuracy are depend on Optional Current Probe (CT) specifications. Current Probe can be selected and obtained by end user fit to end user 'applications' .

- **SOC (State of Charge)**

Range : 0 ~ 100%

Measurement Voltage : Max 300V

Cell Voltage : 1.2V /1.6V/ 1.86V/ 2V/ 3.2V/3.7V/12V

- **Capacity**

Efficiency Measurement : Rated Capacity, Charging / Discharging

Measuring Range : 0 ~100 %

Measuring Capacity : 0 ~ 1200 AH

Max Current : DC 400V

Max Voltage : DC 300V

Display on LCD : Efficiency, Capacity, AH(WH) ,
Average Current, Charging /Discharging Time
Graph.

[Accuracy]

Accuracy of measurement is identified fs(full scale), rdg.(reading), dgt.(digits)

- f.s.(Maximum Measurement value) :

Max measurement value. Maximum on present range.

- rdg.(measurement value) : Present reading value.
- dgt. (Resolution):
Least measurement unit

12.3 Accessories

Standard Accessory

- Pin Type Battery Test Probe (Impedance, Voltage , Temperature measurement):
1 set
- USB Cable : 1
- PC Software : 1
- Operator Manual: 1
- Carrying Bag: 1
- 0 Adjustment Board: 1
- NiMH Battery Pack: 2 x 3.6V NiMH Battery Pack

Optional Accessory

- Clamp Type Battery Test Lead
- DC Current Adapter (40A/400A)

13. Maintenance

[Warning]

Recommend to use qualified personnel to avoid possible Electric Shock or Body Injury.

13.1 General Maintenance

- Clean the Analyzer Case with wet fabrics and detergent periodically.
- Do not use abrasive, Alcohol or solvent. .

- Input Tip area of Test Probe should always be cleaned off. Any foreign material on the tip may cause measurement error.

13.2 Fuse Replacement

[Warning]

To avoid Electric Shock or Body Injury, remove any Input Signal on Test Probe before replace Fuse. Fuse should be replaced with proper rated fuse.

[Replacement Procedure]

- ① Power “ Off” the Analyzer.
- ② Disconnect Test Probe from Battery Terminal.
- ③ Remove Holster Case
- ④ Open Tilt Stand and unscrew the 2 screws at left battery cover and at right battery cover by standard + screw driver.
- ⑤ Unscrew the screw at lower area of Bottom Case.
- ⑥ And Open the Bottom Case.
- ⑦ Remove Used Fuse and replace with New Fuse.
- ⑧ Proceed reverse steps as above

13.3 Battery Replacement

[Warning]

To avoid Electric Shock or Body Injury, remove any Input Signal on Test Probe before replace Battery. Battery should be replaced only with the same Battery Pack supplied with the Analyzer.

[Replacement Procedure]

- ① Power Off Analyzer
- ② Disconnect any Test Probe, Test Lead, Temperature Probe, AC Power Adapter, USB Cable from the Analyzer
- ③ Remove Holster Case

- ④ Open Tilt Stand and unscrew the 2 screws at left battery cover and at right battery cover by standard “+” screw driver.
- ⑤ Unscrew the screw at lower area of Bottom Case. And Open the Bottom Case.
- ⑥ Separate Battery Pack and replace with New Battery Pack.
- ⑦ Make sure to meet (+, -) contact of Battery Pack and (+ -) terminal in the Battery Room. Put the Battery Cover over the original place.
- ⑧ Fix the Screws and assembly of the Bottom Case as reverse step as above

13.4 When Unit is not working

- ① Check Battery Contact and Polarity
- ② Check Case whether any damage.
- ③ Check Fuse and Test Probe, other Test Lead, AC Adapter connecting Analyzer.
- ④ Check Operator Manual whether Unit is working properly.

13.5 Test Probe Pin Replacement

When Tip of the Test Probe is broke, damaged or abrasion, Tip Replacement is available. Purchase Tip only to replace with New Tip

- ① Power Off and separate Test Probe.
- ② Twist the Head Area where Tip.



- ③ Pull in Tip and separate Tip.



- ④ Assembly Tip and Test Probe in accordance with reverse steps as above.
- ⑤ Check whether Measurement with New Tip is no problem and accurate.

To prevent any damage from contact , make sure the cable is tightly connected

And no move when pull in or rotate the cable.

13.6 Cleaning

Use soft fabrics to clean lightly dust with wet with water or detergent. Never use Benzene, alcohol, acetone, ether etc which may change color.

13.7 Scrap

[Warning]

When scrap unit, separate Battery which disposal should be in accordance of rule. To avoid electric shock, Power off and separate battery after Test Probe disconnected.

- ① Power Off and Separate Test Probe
- ② Using Screw Driver, separate Screw on Battery Cover.
- ③ Separate Battery Pack.